

Tegometall

New Versatility in Shopfitting

Assembly instructions for shopfitting shelving

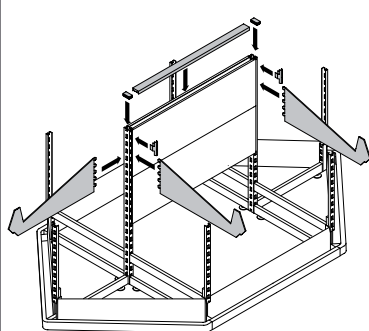
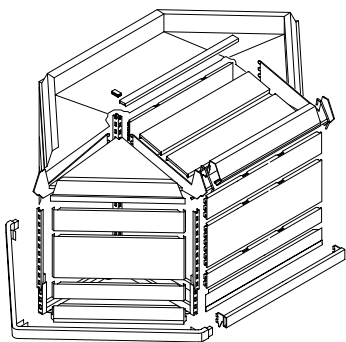
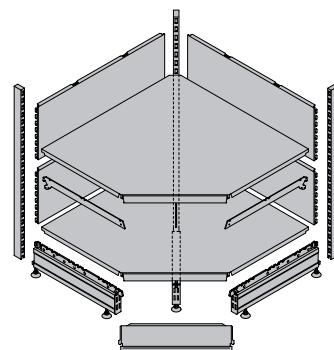
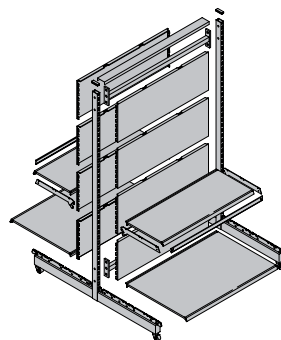

Chapter overview

Chapter 1	General information	3
Chapter 2	Assembly instructions for shelves and gondolas	7
Chapter 3	Assembly instructions for fruit and vegetable shelves	23
Chapter 4	Assembly instructions for fruit gondola with one or two shelves	29
Chapter 5	Permissible loads	35

Chapter 1	General information	
	1 Important information	4
	2 Notes on accident prevention	4
	3 Liability claim/warranty	5
	4 Environmental note/disposal	5
	5 Special notations, representations, and pictograms	5
	6 Important tips and information before assembly and installation	6
	7 Technical information	6

**Tegometall
International Sales GmbH**

Industriestraße 7
CH-8574 Lengwil-Oberhofen
Telephone +41 (0) 71 6 86 93 60
Fax +41 (0) 71 6 86 93 77
Info@tegometall.com
www.tegometall.com

Technical status: March 2023

1 Important information

- The assembly steps in these assembly instructions are described without text. Certain procedures are explained with pictograms. For the meaning of the individual pictograms, please refer to the pictogram overview on page 5.
- The regulations and load values described in these operating and assembly instructions apply only to shelving units which are located in rooms which are closed on all sides and at a moderate temperature (>5°C). The load limits can be found in these operating and assembly instructions.
- The regulations and instructions of these assembly instructions must be implemented during assembly, commissioning, or use of the shelves and gondolas as well as fruit and vegetable shelves. If you have any questions or need technical support, please contact Tegometall International Sales GmbH.

2 Instructions for accident prevention

When assembling and using the shelves and gondola shelving, as well as fruit and vegetable shelves, it is essential to observe the following:

- In principle, the general accident prevention regulations and, in particular, the guidelines "Storage facilities and equipment", Industry Rules for Occupational Safety and Health – BGR 234, as amended, must be complied with.
- All relevant applicable accident prevention regulations.
- The generally recognised safety rules.
- When assembling and planning shelving equipment, the guidelines for storage facilities and equipment of the respective country must be observed.
- ☒The shelving systems may only be used for the intended purpose as described.
- ☒The technical rules, in particular the manufacturer's guidelines in these operating and assembly instructions, must be observed.
- ☒Climbing on the shelving is prohibited.



Please note!

The pictorial representation of the shelves and shelf parts in these instructions may differ slightly from the delivered shelf as a result of technical progress. This has no influence on the content and meaning of these assembly instructions – the assembly instructions must be observed in any case.



Please note!

In case of unauthorised installation or modification, as well as mixing with load-bearing or securing parts of other manufacturers, we reject any liability.



Please note!

We reserve the right to colour deviations and technical changes, which are necessary due to further development.

3 Liability claim/warranty

- Compliance with official regulations and safety instructions is a prerequisite for liability claims.
- Failure to comply with the official regulations and the safety instructions will result in exclusion of liability on the part of the manufacturer.

4 Environmental note/disposal

Old and defective components as well as the packaging materials can be separated by type so that they can be disposed of in an environmentally friendly manner or recycled as required.

5 Special notations, representations, and pictograms

In these instructions, different facts are highlighted by special notations and pictograms. For meaning and appropriate action, see the following examples.

Special notations and representations

- This square "■" indicates a listing introduced by a heading.

Pictograms



Regulation

This notice draws your attention to a legal requirement. Failure to observe this notice will result in the exclusion of warranty and liability on the part of Tegometall International Sales GmbH.



Attention

This notice indicates a dangerous situation for people and/or the product. Failure to follow this instruction may result in personal injury and/or damage to the shelves.



Make sure it clicks into place

When installing these shelving parts, make sure that they are securely locked in place. If this is not the case, the components are not properly connected and personal injury and/or damage to the shelves may result.



Ensure a secure connection

When installing these shelving parts, make sure that they are securely connected. If this is not the case, the components are not properly connected and personal injury and/or damage to the storage facility may result.



Please note!

This note provides you with application recommendations and helpful tips.



Do not assemble with each other

Shelving parts marked with this pictogram must not be assembled with each other.



Must be mounted

Shelving parts marked with this pictogram must be mounted. They are important for the stability of the rack.



Shelving part can be omitted

Te części regału nie mają wpływu na jego stabilność.



Important

For assembly steps marked with this pictogram, fastenings must be made with bolts, nuts, and dowels of specific dimensions.



Wall mounting with wall-mount upright

The assembly step refers to shelving parts assembled with wall-mount uprights.



Wall mounting with upright and baseleg

The assembly step refers to shelving parts that are assembled with columns and baselegs and fixed to the wall.



Free standing half gondola, fixed/mobile

The assembly step refers to shelving sections assembled with columns and baselegs. A half gondola stands freely.



Freestanding gondola, fixed/mobile

The assembly step refers to shelving sections assembled with uprights and baselegs. A gondola stands freely.



Note on the 90° inside corner

When assembling the 90° inside corner, three columns, baselegs and brackets are required in each case.



Repeat assembly steps

Carry out the assembly steps as described in Chapter 1 – Item 6 "Important tips and information before assembly and installation".



Assembly sequence

Sequence of assembly in the assembly procedure



Assembly step



Sequence of assembly steps within an assembly sequence.

6 Important tips and information before assembly and installation

We recommend sorting the boxes and packages in the following order before assembly.

The assembly is to be carried out in the same order:

1. Uprights and baselegs, wall-mount uprights
2. Plinthes
3. Back panels
4. Shelf brackets
5. Shelves
6. Additions
7. Accessories

These illustrations show different space situations. We recommend assembling the shelves in the given order (a, b, c...). For shelves with corner elements, the assembly should be started with them.

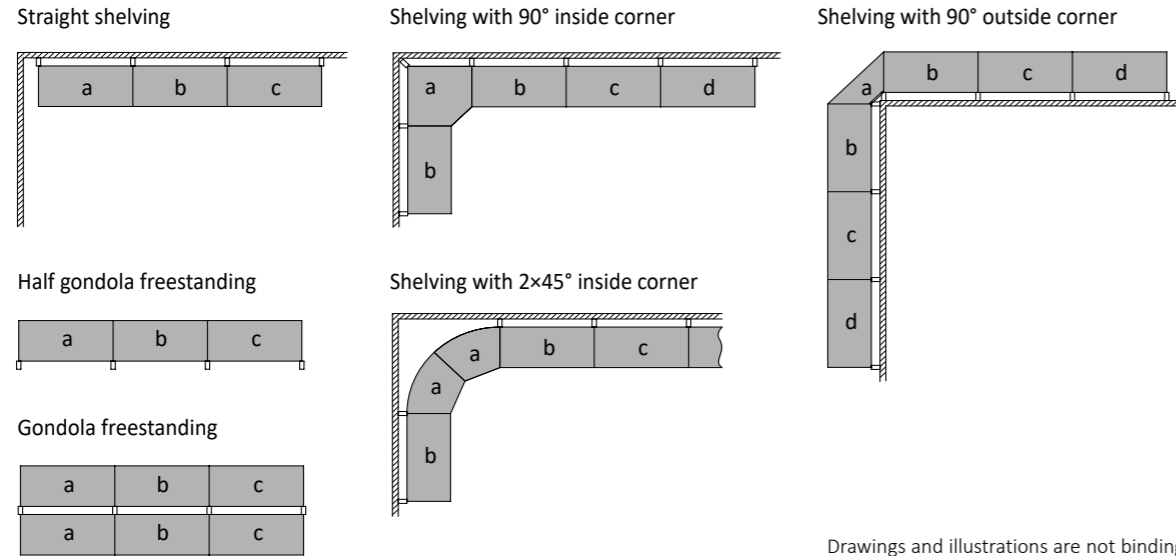

Drawings and illustrations are not binding.

7 Technical notes

Zusammensetzung der Artikel-Nummern

Example:
 Baseleg, H 7, white = **21 3349 01 V**
 21 3349 01 V = product group
 21 **3349** 01 V = base product number
 21 3349 **01** V = execution key
 21 3349 01 **V** = packaging unit
 21 3349 01 **P** = pair

Dimensions

The dimensions given are usually nominal dimensions.

The abbreviations mean the following:
 H = height
 L = length
 D = depth
 W = width
 Ø = diameter

Wymiary w osiach – wymiary nominalne

The exact axis dimension is

at L 66.5 cm = **66.65cm**
 at L 100 cm = **100cm**
 at L 125 cm = **125cm**
 at L 133 cm = **133.3cm**

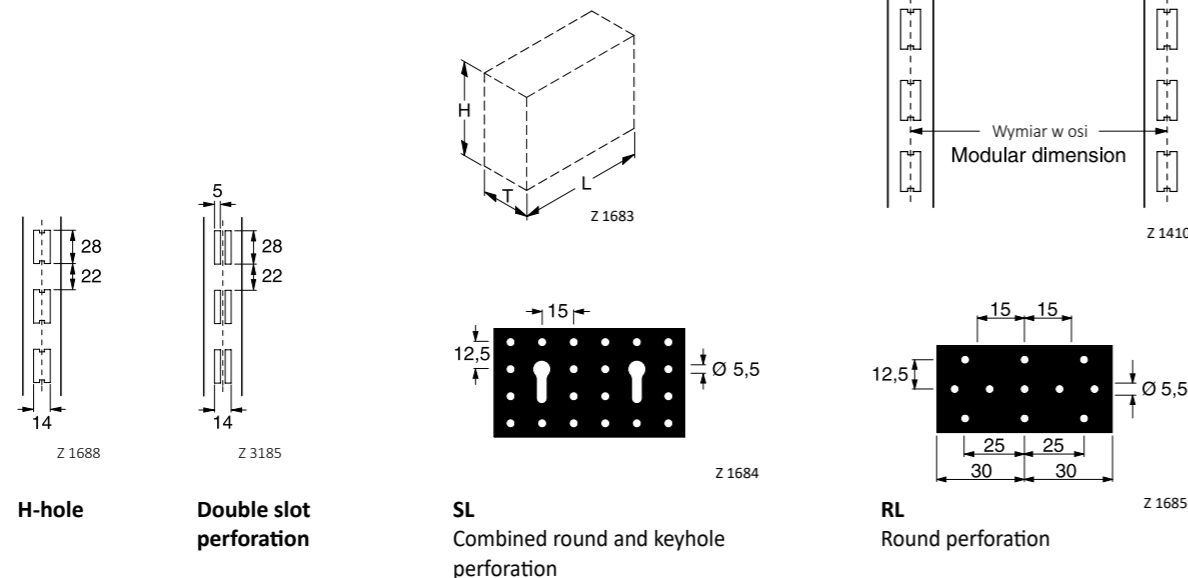

Chapter 2

Assembly instructions for shelves and gondolas

1	Overview of shelving components and their function	8
2	Depiction of the shelving components and their function	9
2.1	Shelving components for shelves and gondolas/mobile gondolas.....	9
2.2	Shelving components for internal and external corners	10
2.3	Accessories	10
3	Assembly of base shelves and gondolas/mobile gondolas.....	11
3.1	Connecting baselegs with columns	11
3.2	Wall mounting	11
3.3	Plinthes installation	12
3.4	Crash bar installation.....	12
3.5	Back panel mounting.....	13
3.5.1	One-sided back panel mounting.....	14
3.5.2	Double-sided back panel mounting.....	14
3.6	Shelves.....	15
3.7	Glass shelves.....	15
4	Assembling the corners for base shelves and gondolas	16
4.1	Inside corners and outside corners	16
5	Assembling the fascia for base shelves and gondolas	17
5.1	Metal and wood fascia	17
5.2	Fascia with light fitting.....	17
5.3	Fascia for inside corners, round.....	18
5.4	Fascia for inside corners, 90°	18
5.5	Fascia for outside corners.....	18
6	Mounting the wall-mount uprights	19
6.1	Wall-mount uprights	19
6.2	Attaching the holders	20
7	Mounting the accessories	20
7.1	Shelf dividing plate	20
7.2	Compartment grids and divider grids.....	20
7.3	Gondola shelving face, single-sided back panel	21
7.4	Gondola shelving face, double-sided back panel	22

1 Overview of shelving components and their function

- 1 Upright – for hanging the baselegs, shelf brackets, and back panels.
- 2 Back panel – rear facing.
- 3 Fascia support – for attaching the upper fascias
- 4 Fascia – upper cover.
- 5 Shelf bracket – for hanging the shelves.
- 6 Shelf.
- 7 Price rail – for inserting price labels.
- 8 Baseleg – support of the column.
- 9 Plinth – bottom facing.
- 10 Crash bar – protects the shelf from approaching shopping carts.
- 11 Gondola front side frame – for attaching a side shelf.
- 12 End cap for upright – top cover of the upright.
- 13 Gondola cover strip – covers the gap between back panels.
- 14 Tie-bar – to improve the stability of the shelving.
- 15 Mobile half gondola stand – mobile upright with baseleg.
- 16 Mobile gondola stand – mobile upright with baseleg.
- 17 Round back panel – rear facing for round inner corners 45°.
- 18 Shelf inside corner 45°, round.
- 19 Back panel, external corner 90°.
- 20 Shelf outside corner 90°.
- 21 Shelf inside corner 90°.
- 22 Wall-mount upright – for direct mounting on the wall for attaching brackets and back panels.
- 23 Back panel SL – for hanging and mounting hooks and holders.
- 24 Divider plain.
- 25 Dividing strip.
- 26 Divider plain.
- 27 Subdivider.
- 28 Front grid – for dividing a shelf.
- 29 Divider grid – for dividing a shelf.
- 30 Angled bracket for wood and glass shelves.
- 31 Connection bar.
- 32 Glass support.
- 33 Glass shelf.

2 Depiction of the shelving components and their function

2.1 Shelving components for shelves and gondolas/mobile gondolas

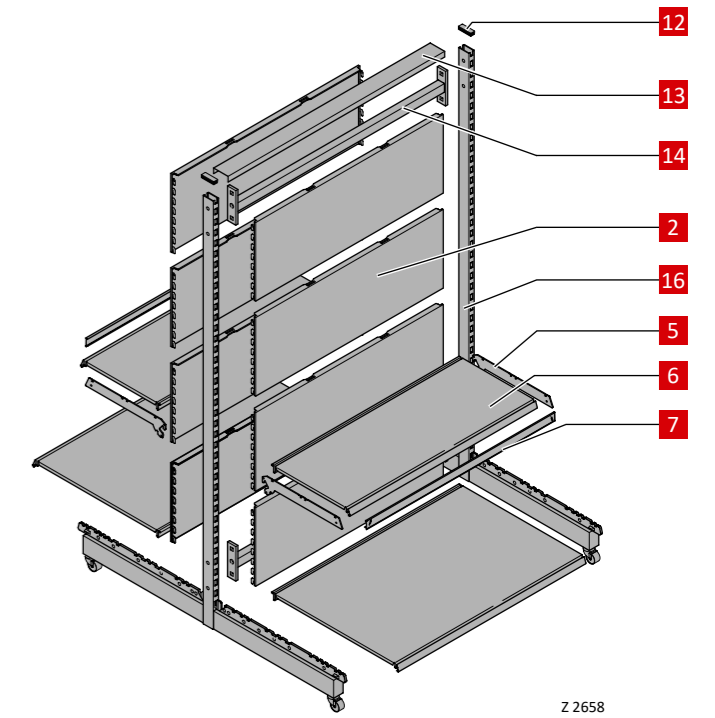
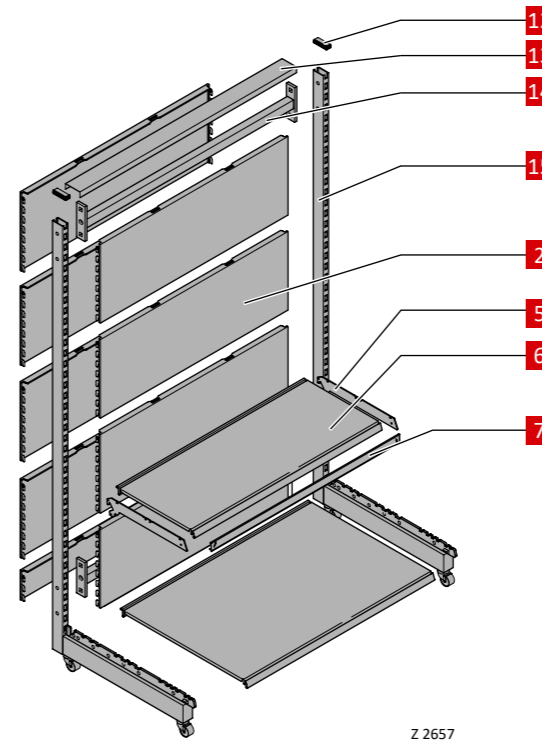
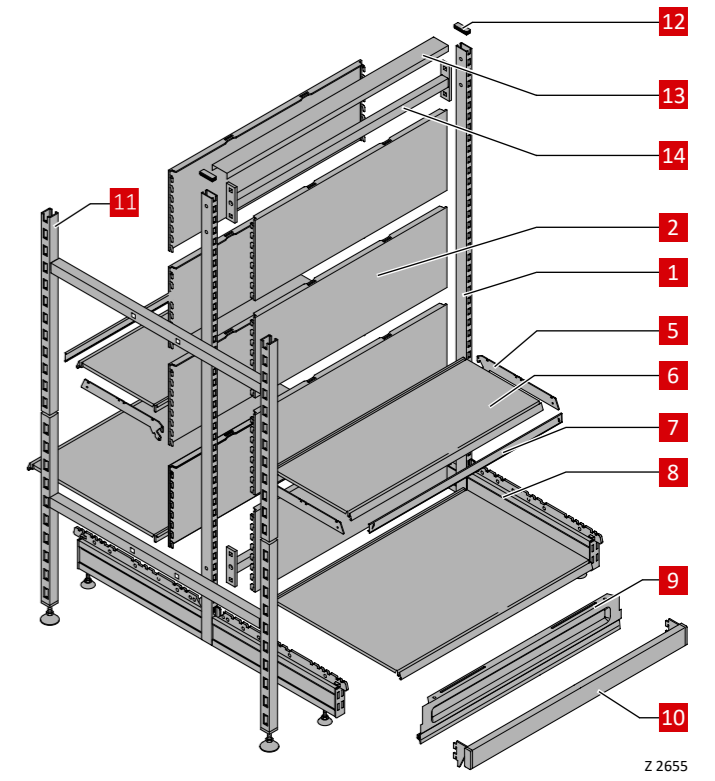
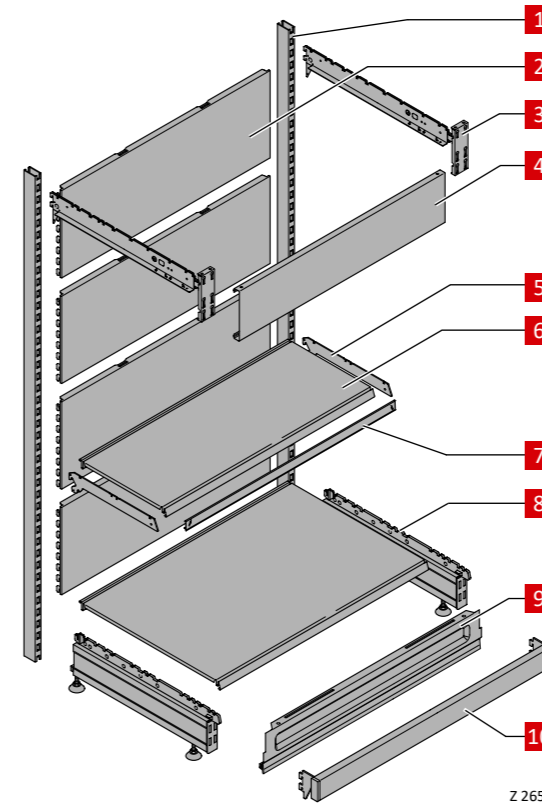

Assembly instructions for shelves and gondolas

2.2 Shelving components for internal and external corners

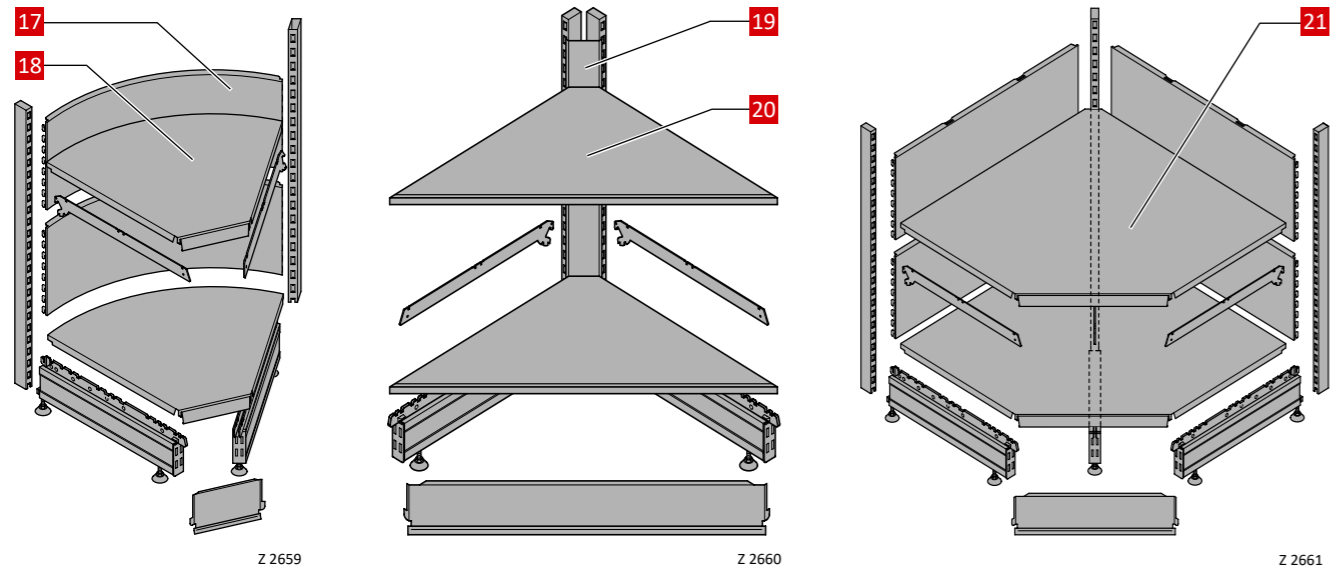

2.3 Accessories

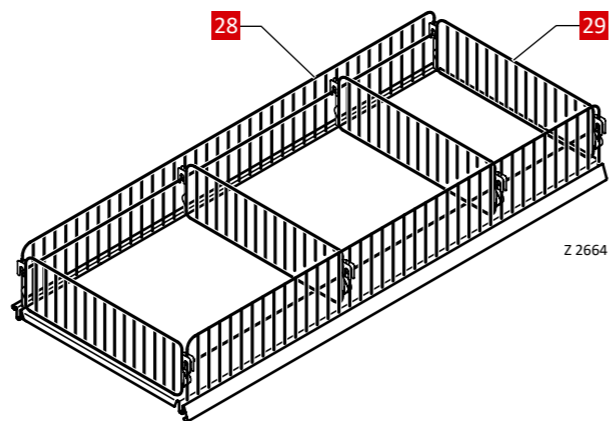
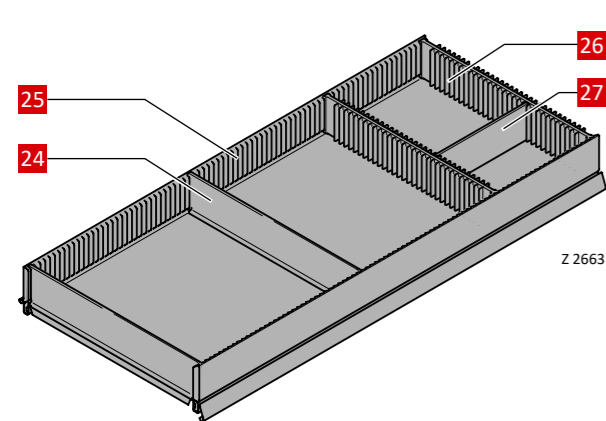
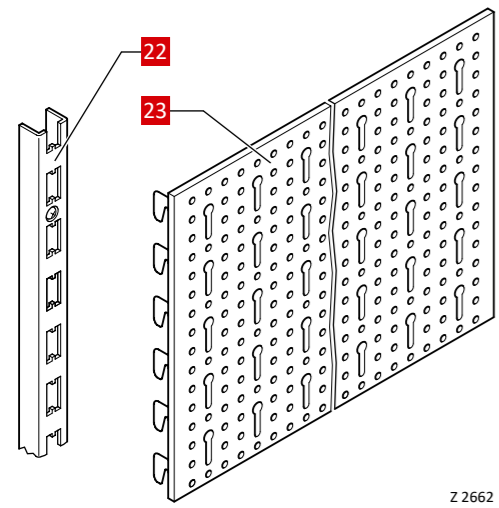

3 Assembly of base shelves and gondolas/mobile gondolas

3.1 Connecting baselegs with uprights

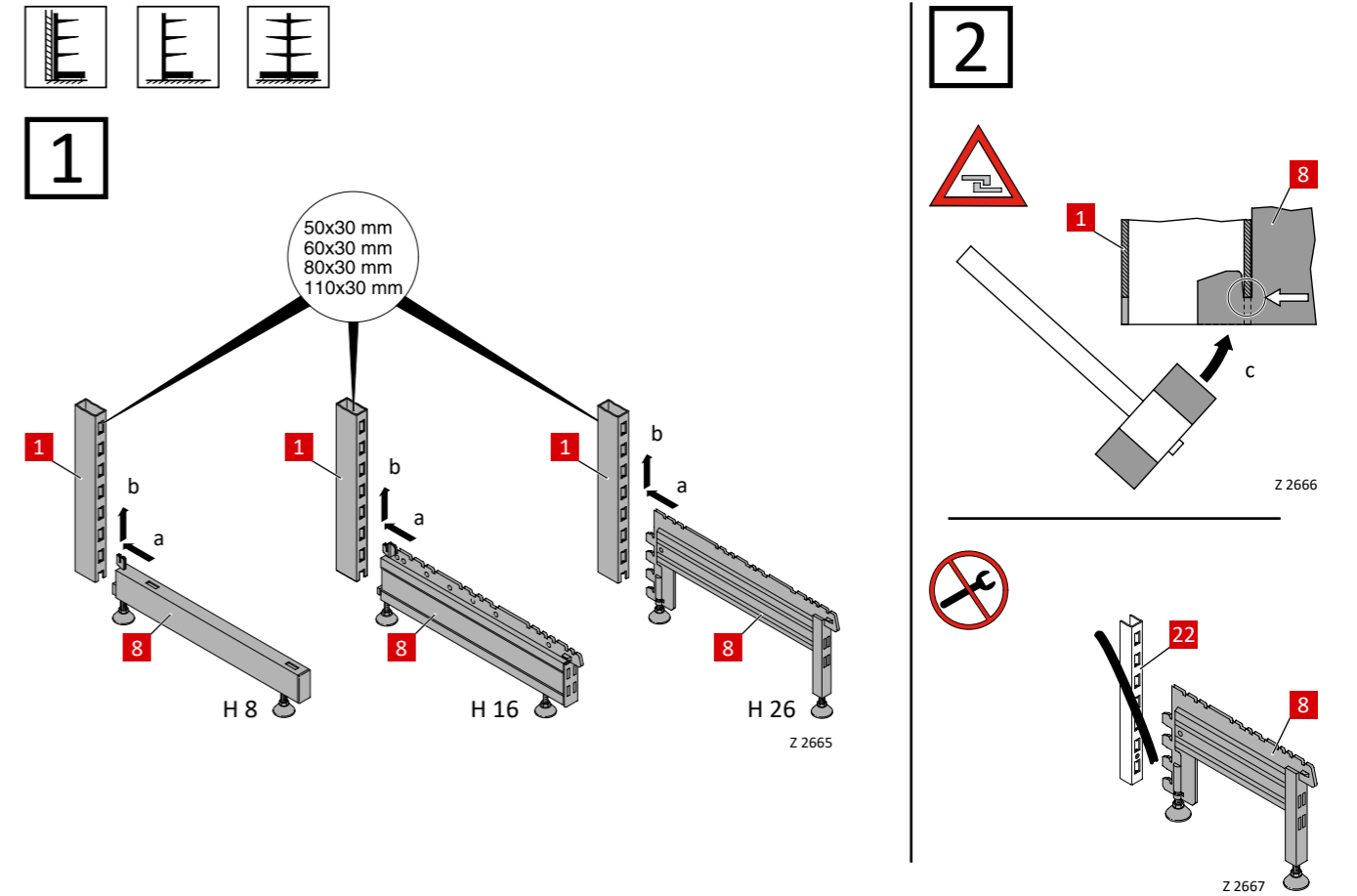

3.2 Wall mounting

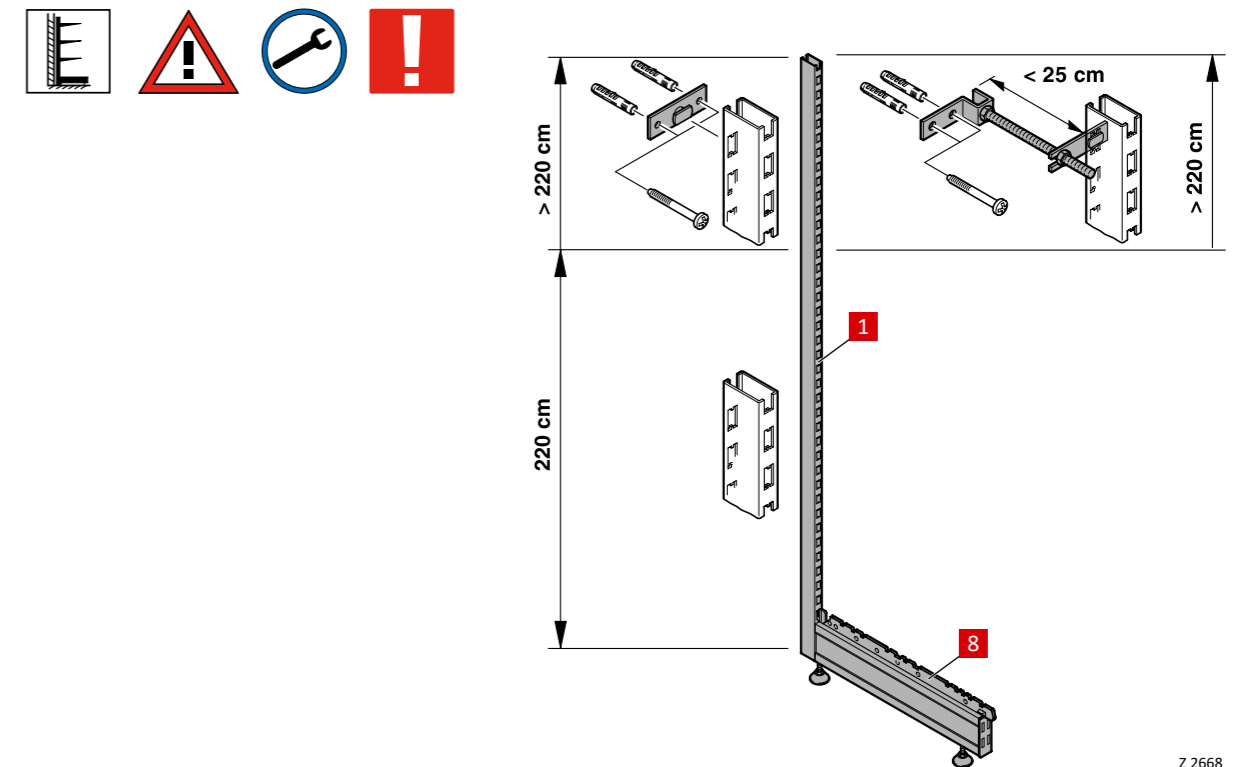

3.3 Plinthes installation

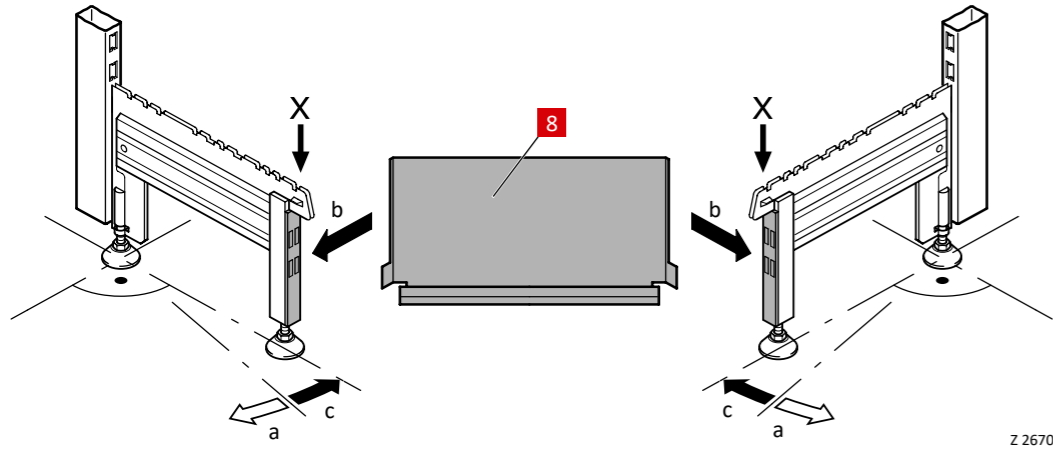
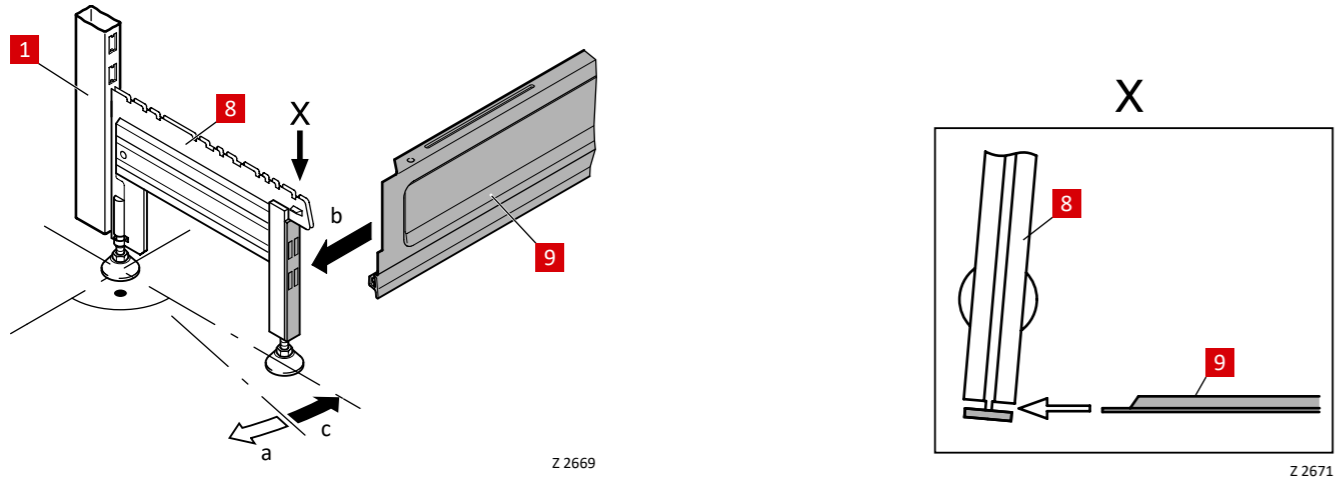
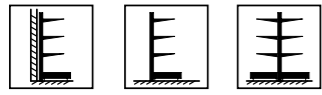

3.4 Crash bar installation

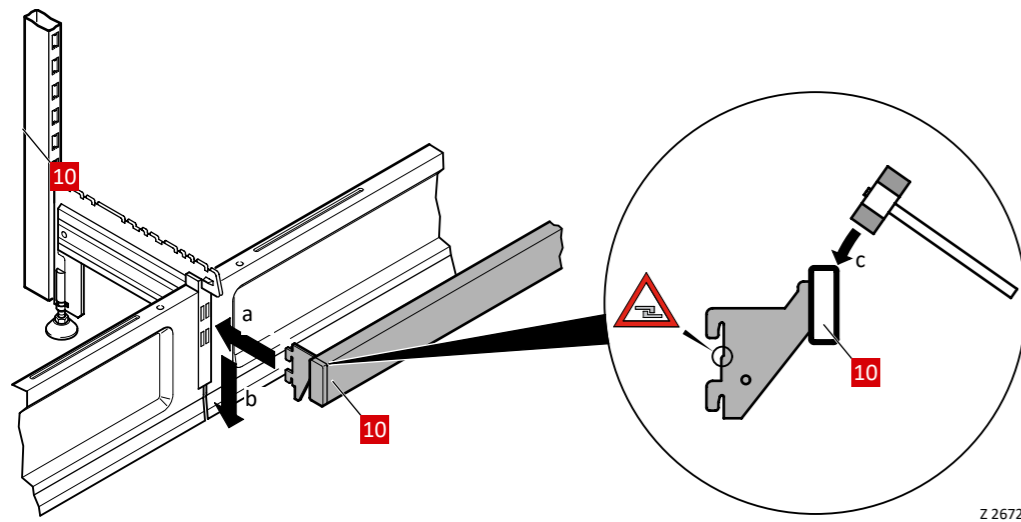
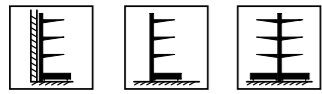

3.5 Back panel mounting

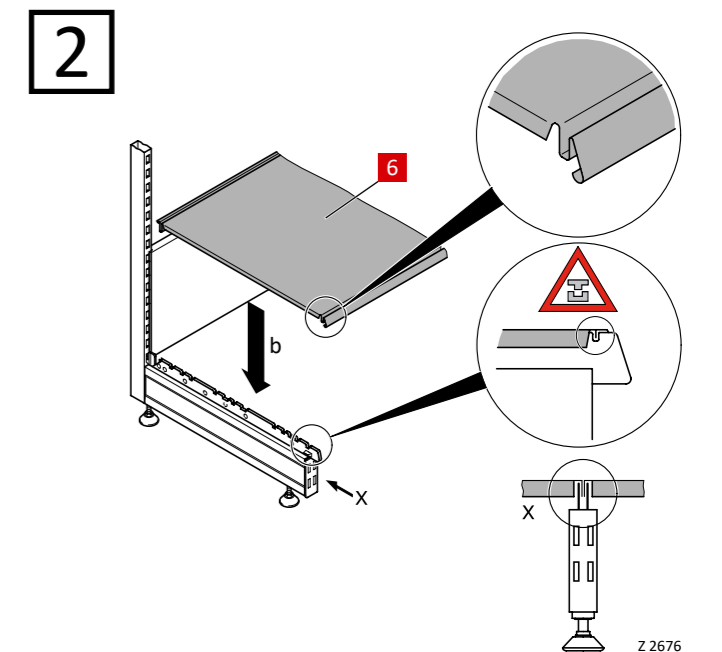
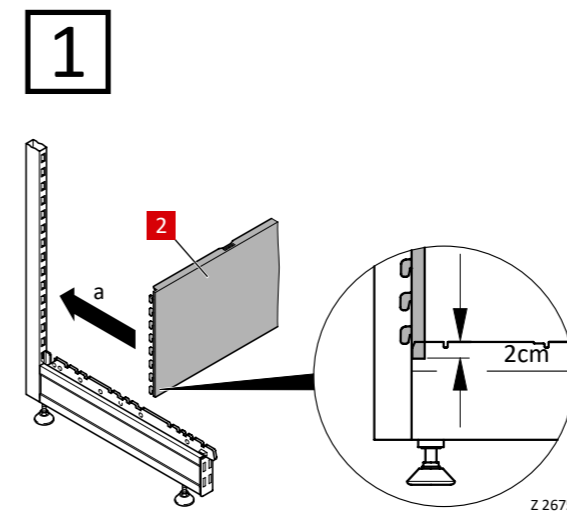
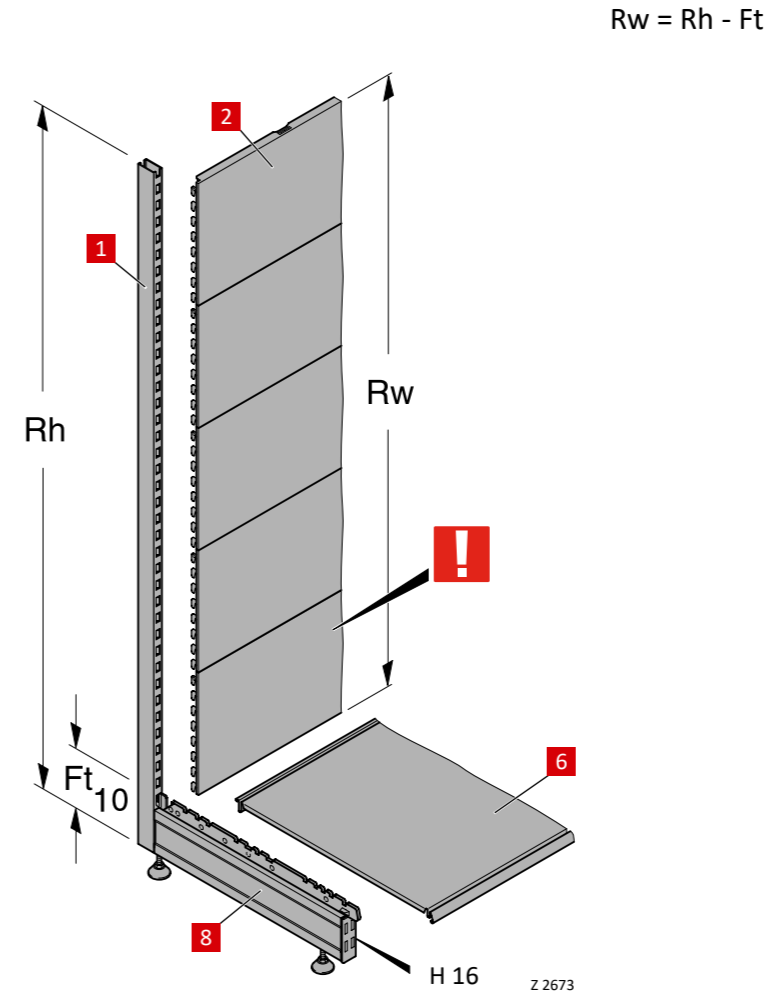
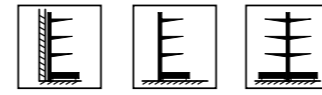

3.5.1 One-sided back panel mounting

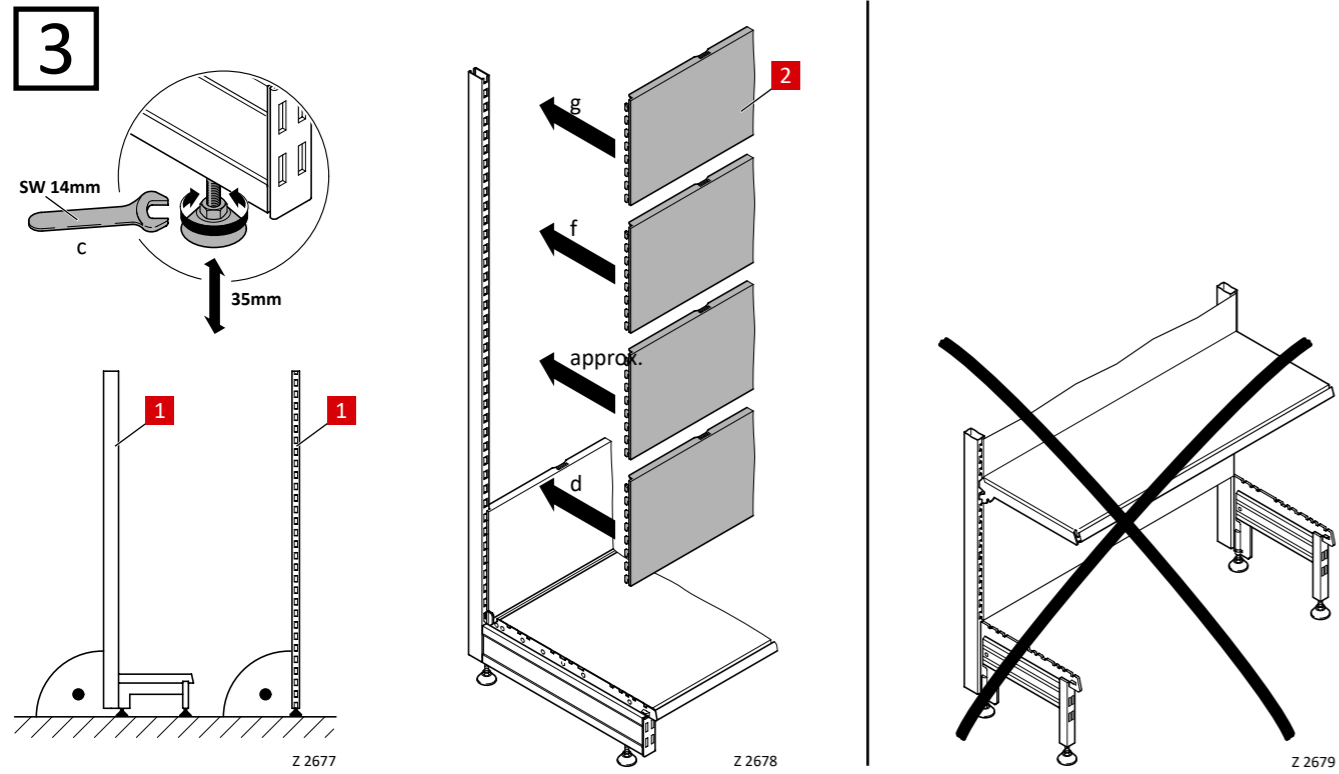
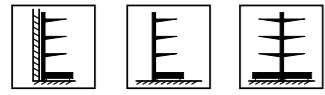

3.5.2 Double-sided back panel mounting

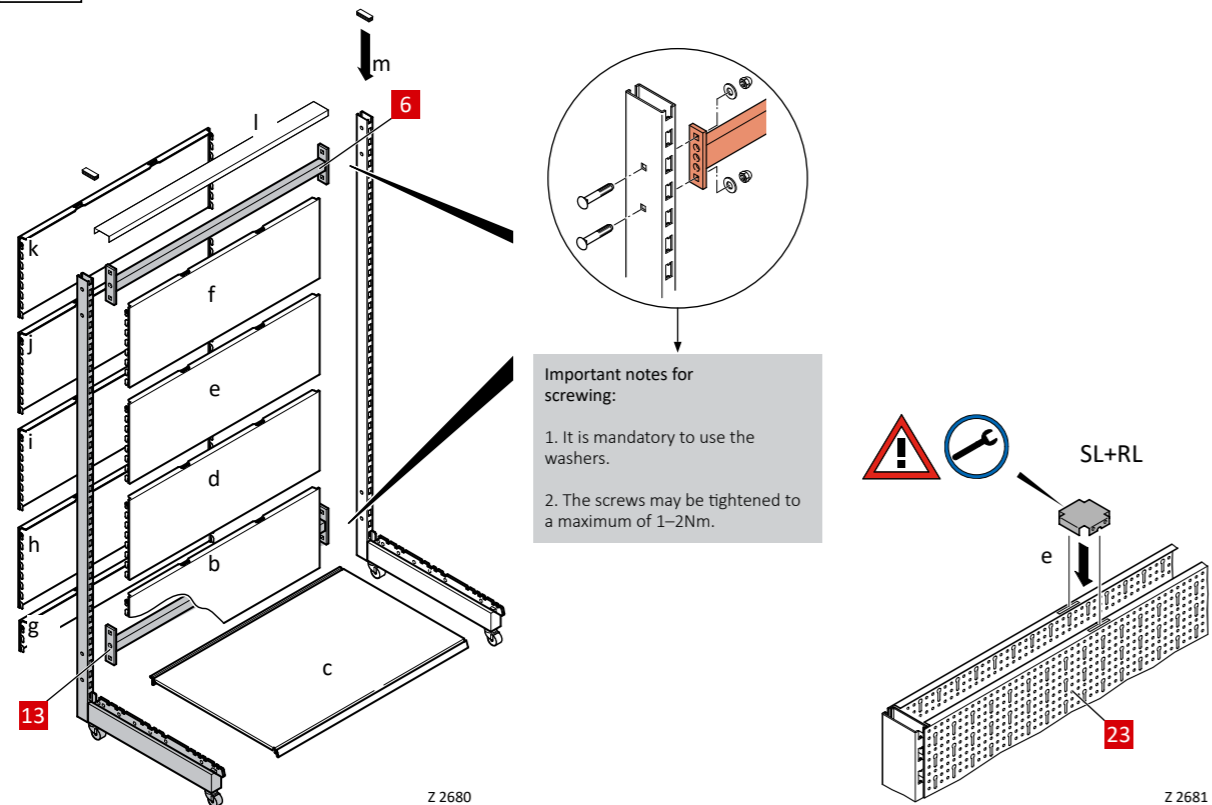
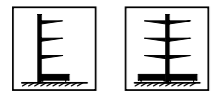

3.6 Shelves

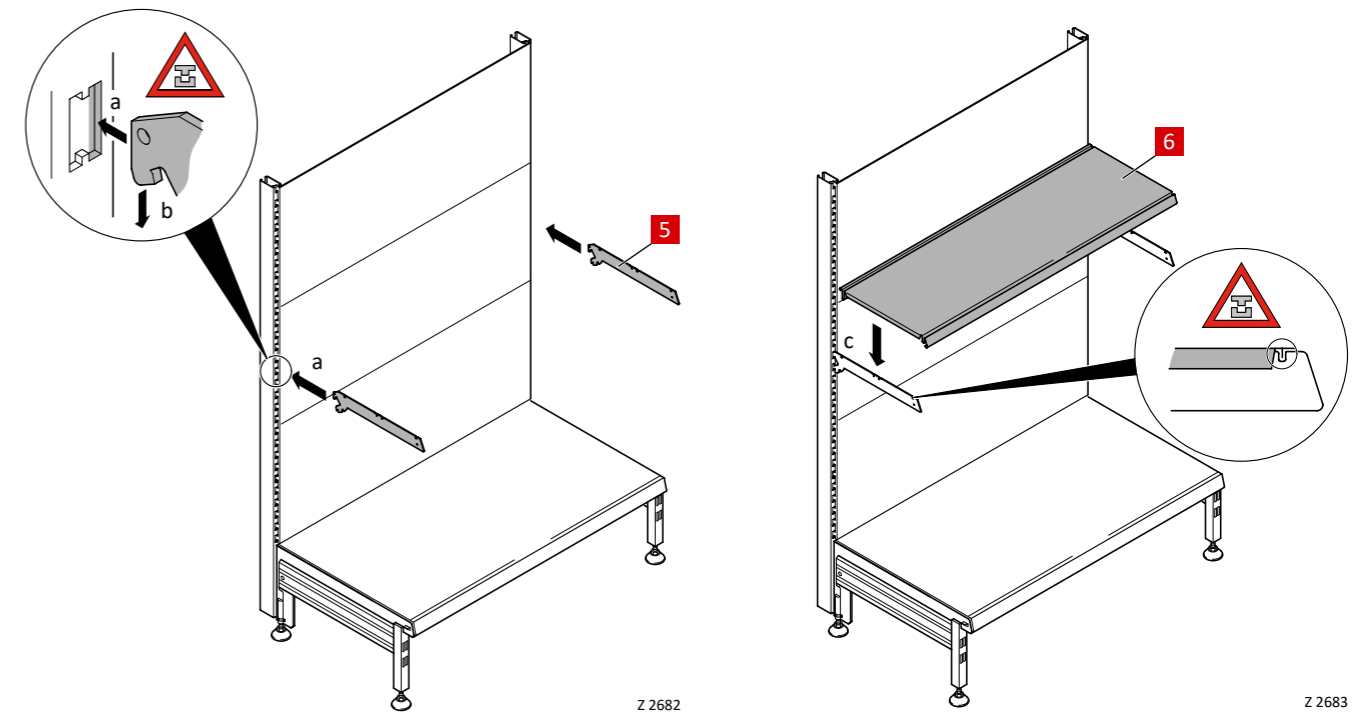
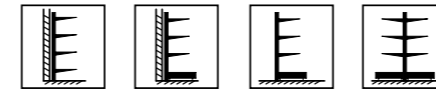

3.7 Glass shelves

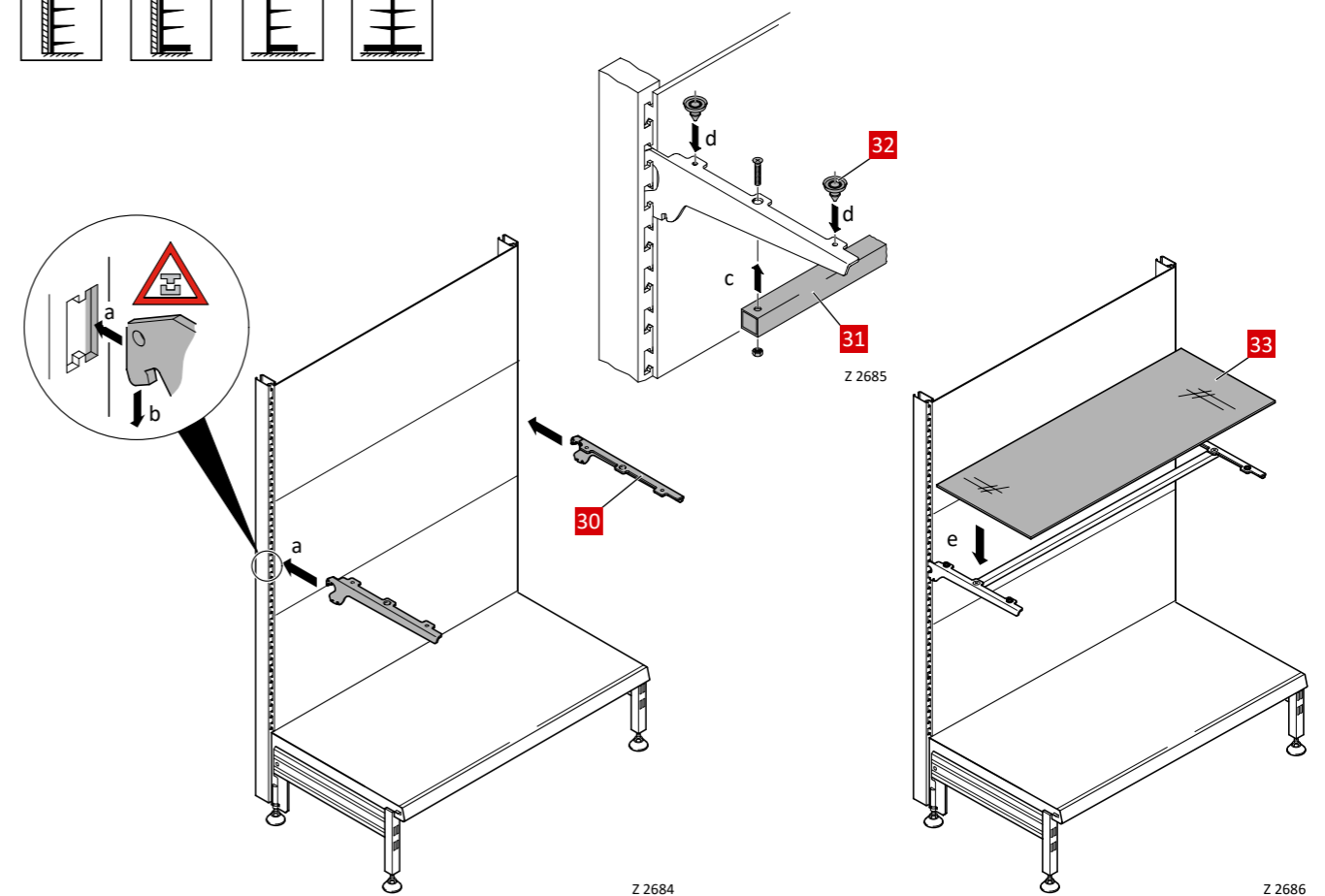
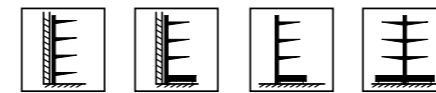

4 Assembling the corners for base shelves and gondolas

4.1 Inside corners and outside corners

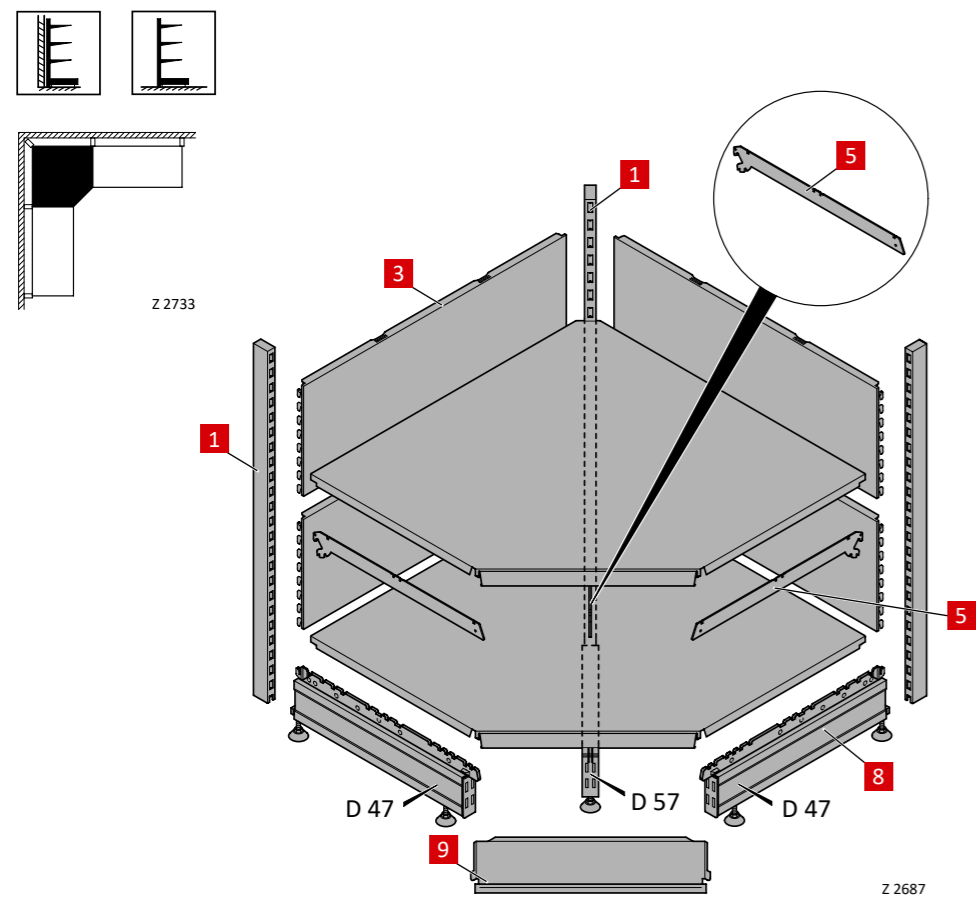
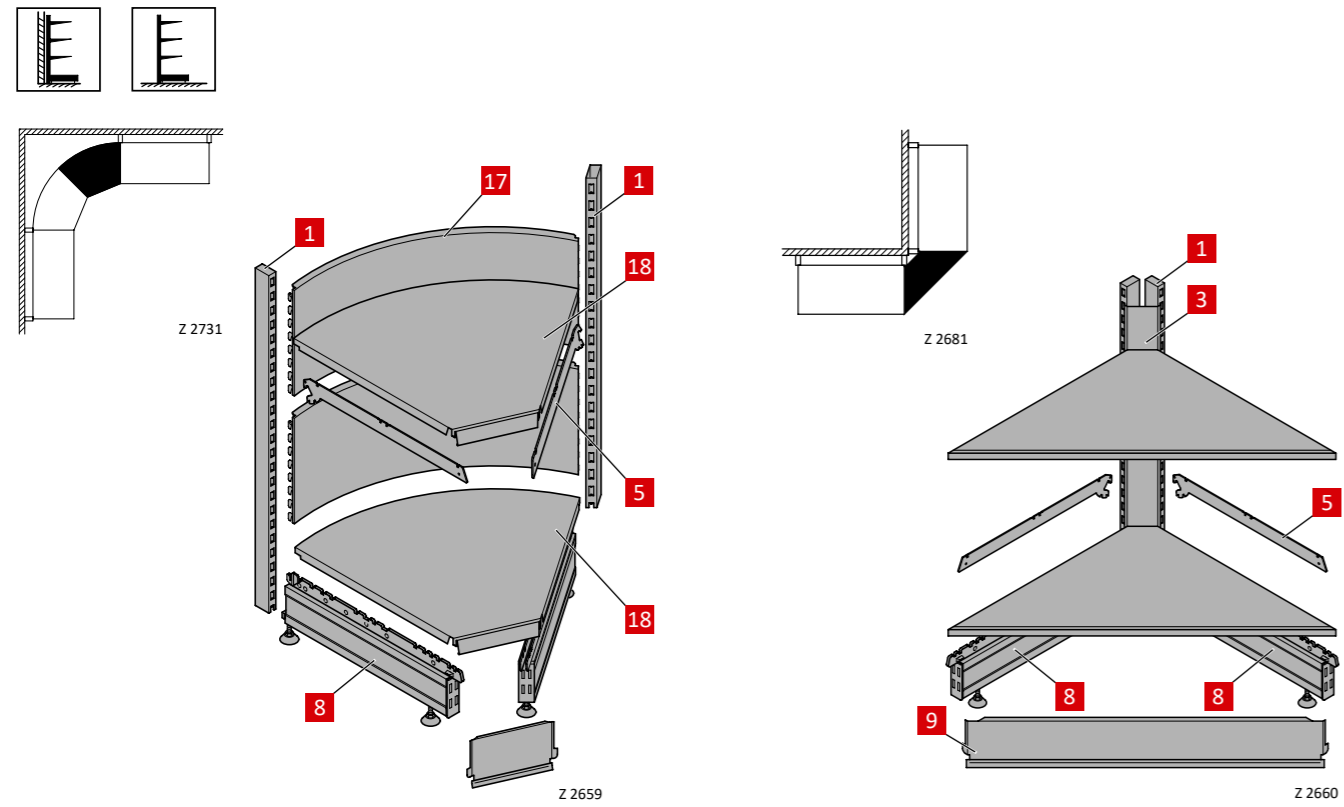

5 Assembling the fascia for base shelves and gondolas

5.1 Metal and wood fascia

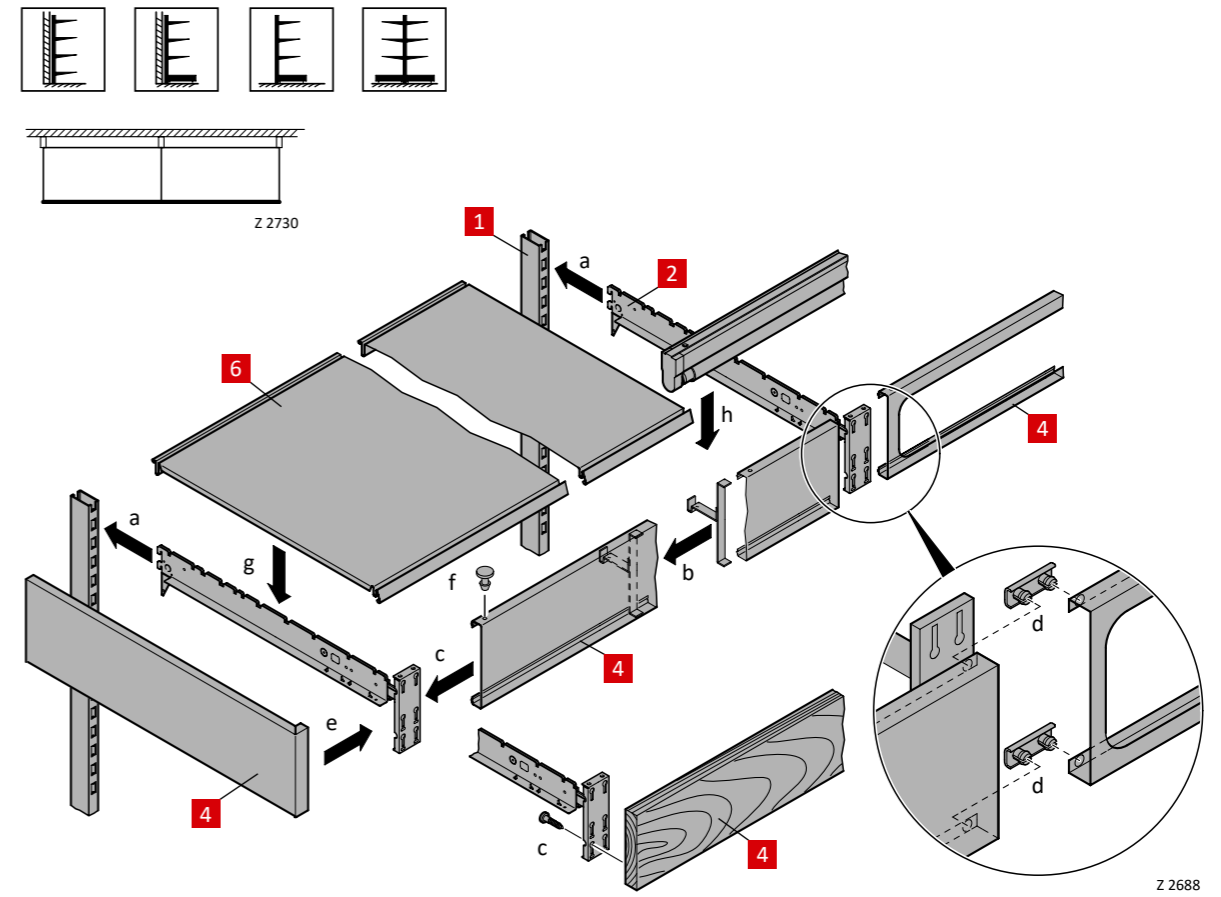

5.2 Fascia with light fitting

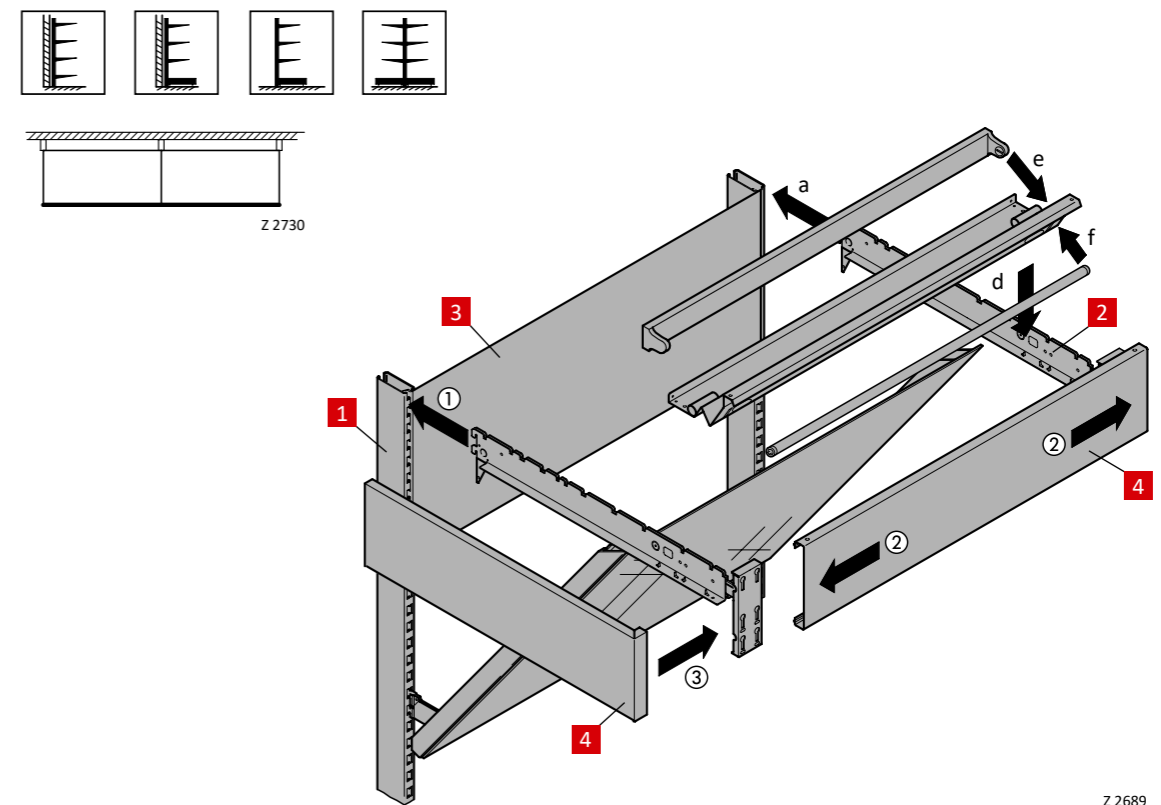

Assembly instructions for shelves and gondolas

5.3 Fascia for inside corners, round

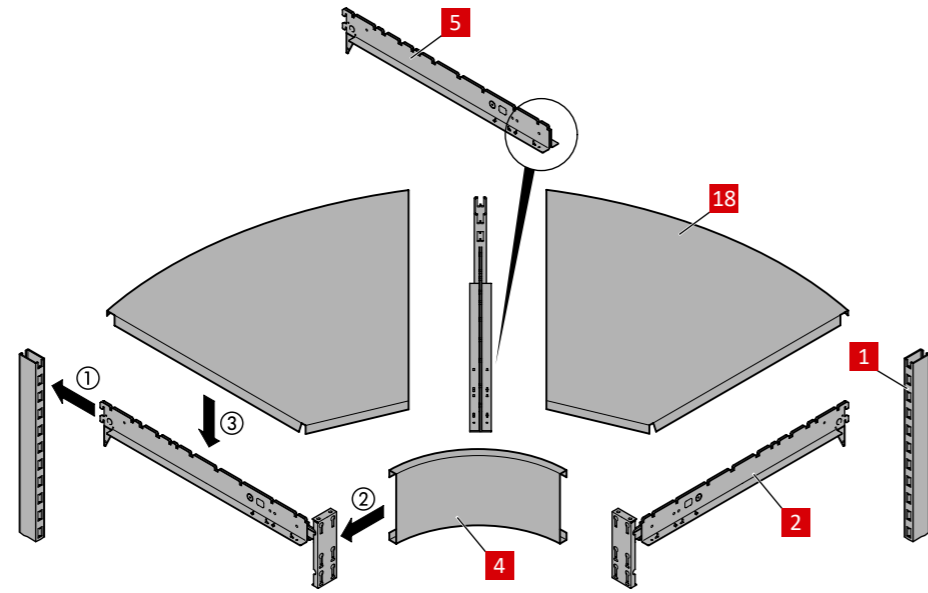
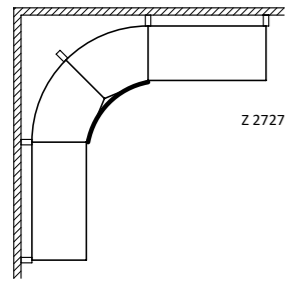
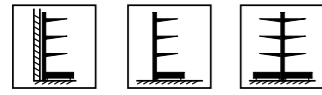

Z 2690

5.4 Fascia for inside corners, 90°

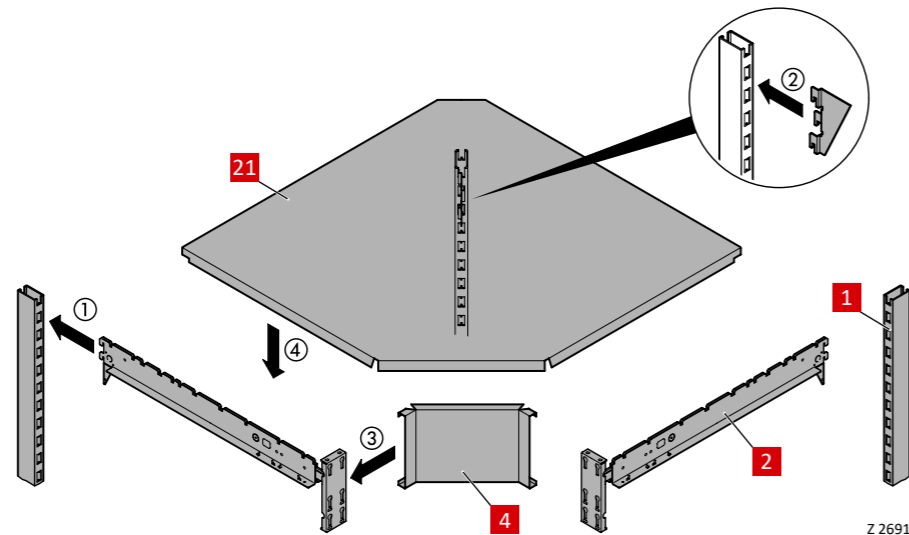
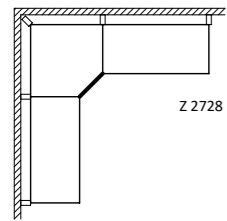
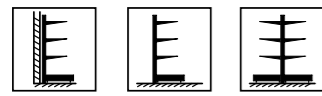

Z 2691

5.5 Fascia for outside corners

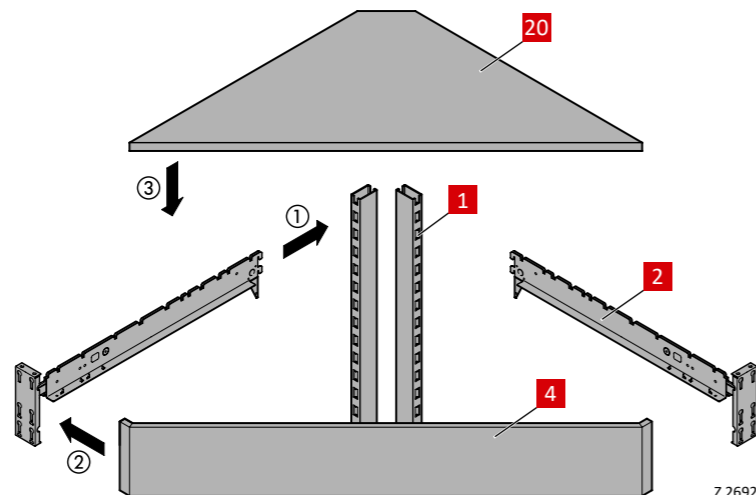
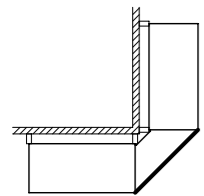
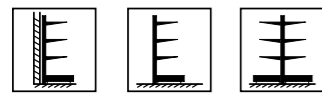

Z 2692

6 Mounting the wall-mount uprights

6.1 Wall-mount uprights



Attention

The wall must be able to absorb the forces generated by the wall-mount uprights.



Attention

When using system parts, pay attention to the axial dimensions.

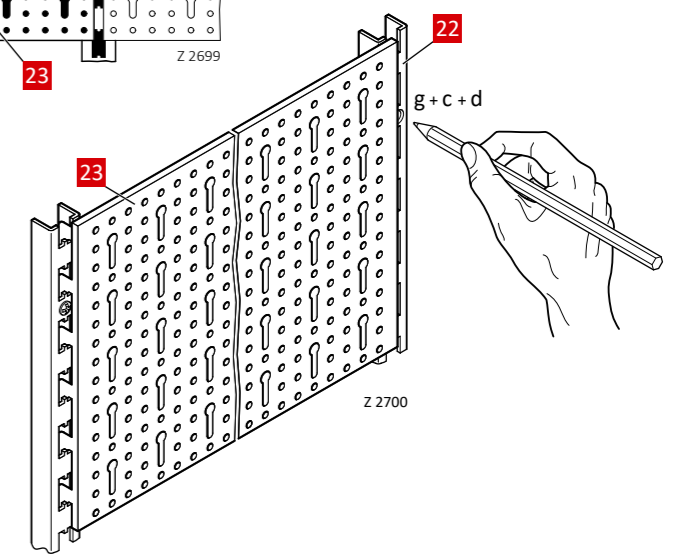
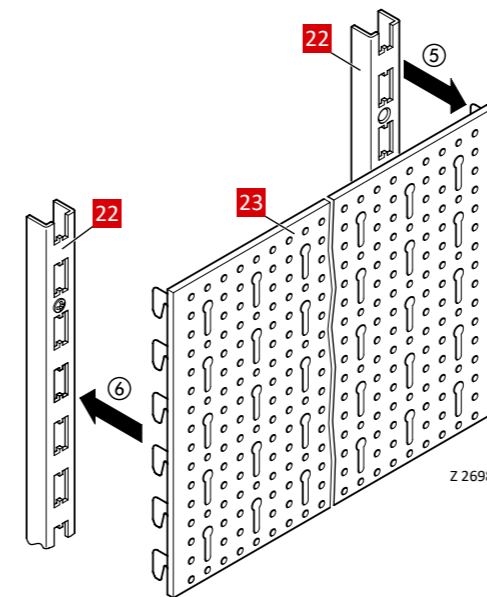
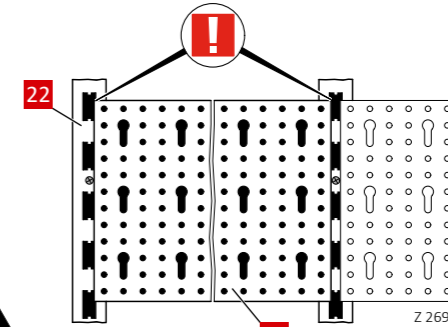
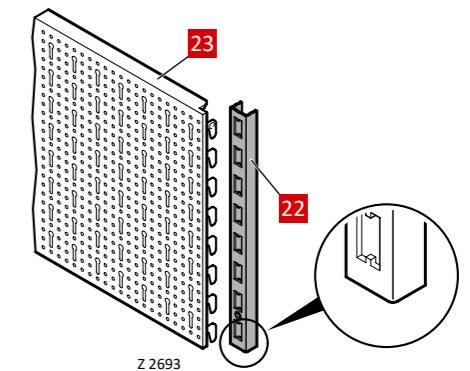
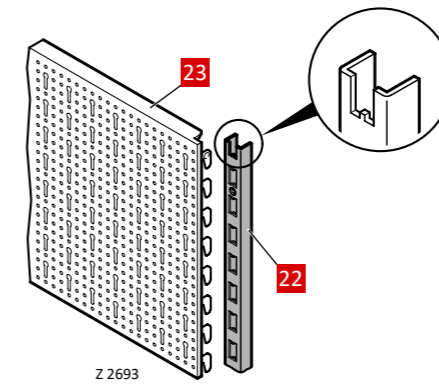
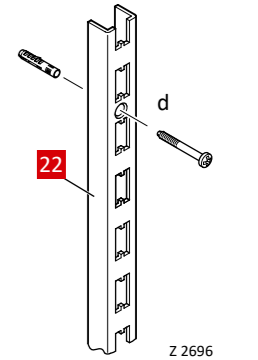
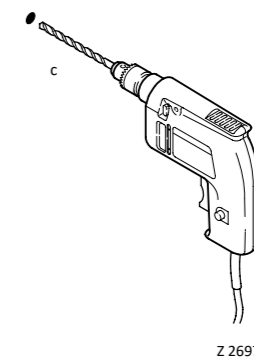
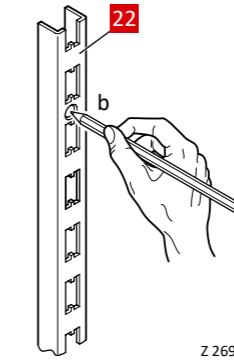
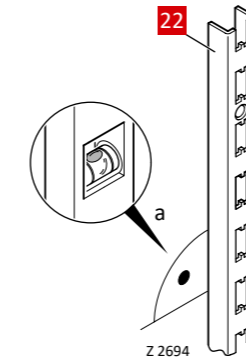

Assembly instructions for shelves and gondolas

6.2 Attaching the holders

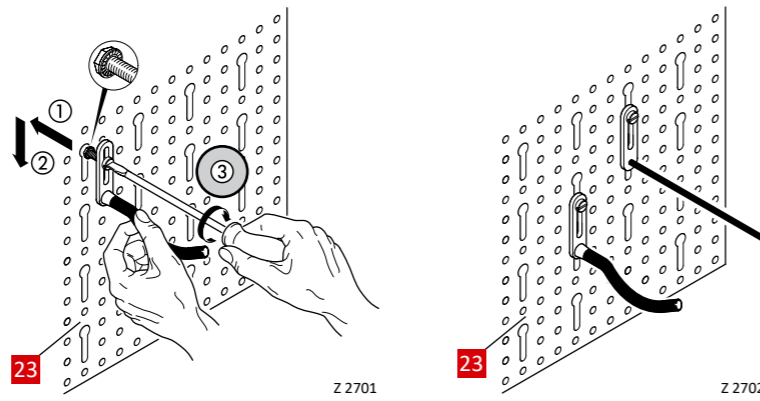
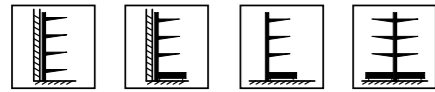

7 Mounting the accessories

7.1 Shelf dividing plate

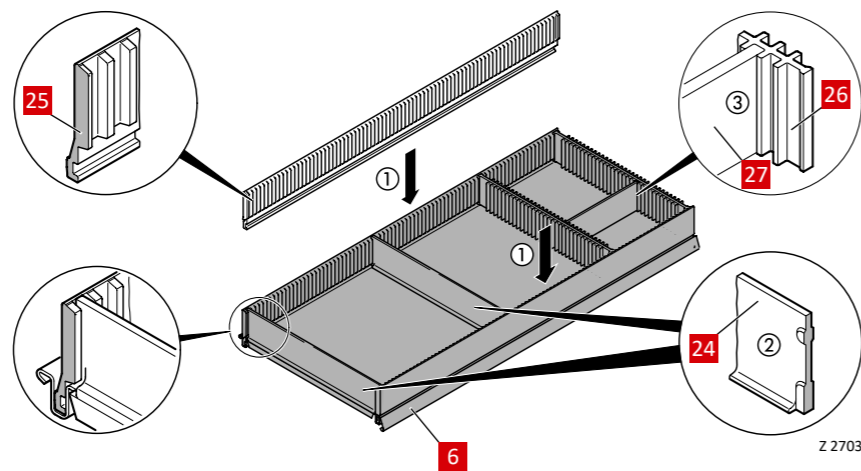
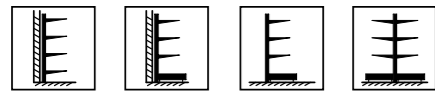

7.2 Compartment grids and divider grids

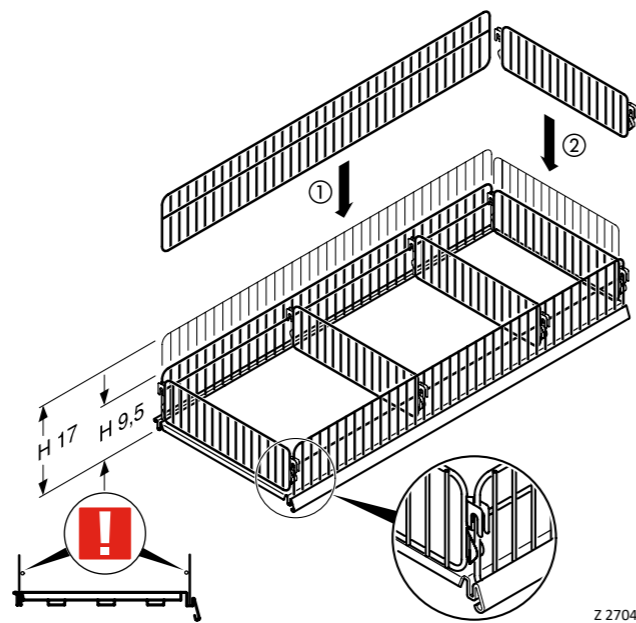
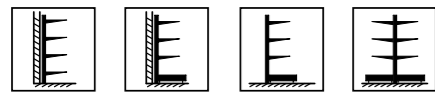

7.3 Gondola shelving face, single-sided back panel

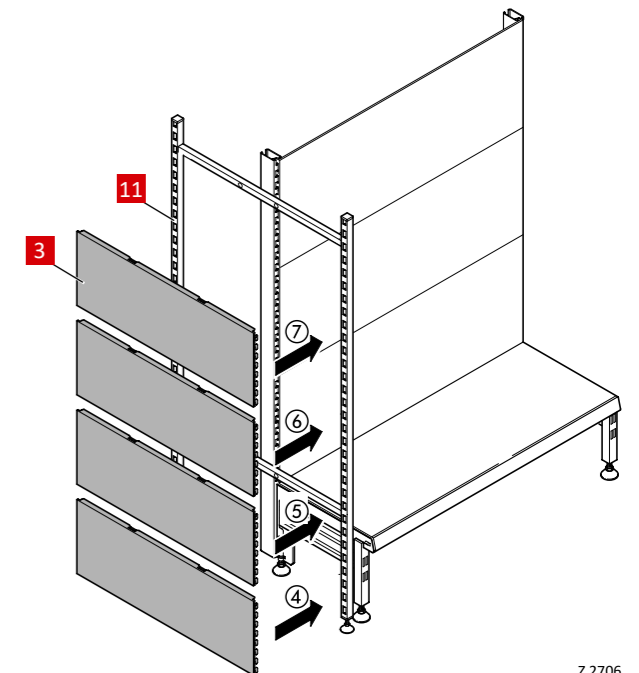
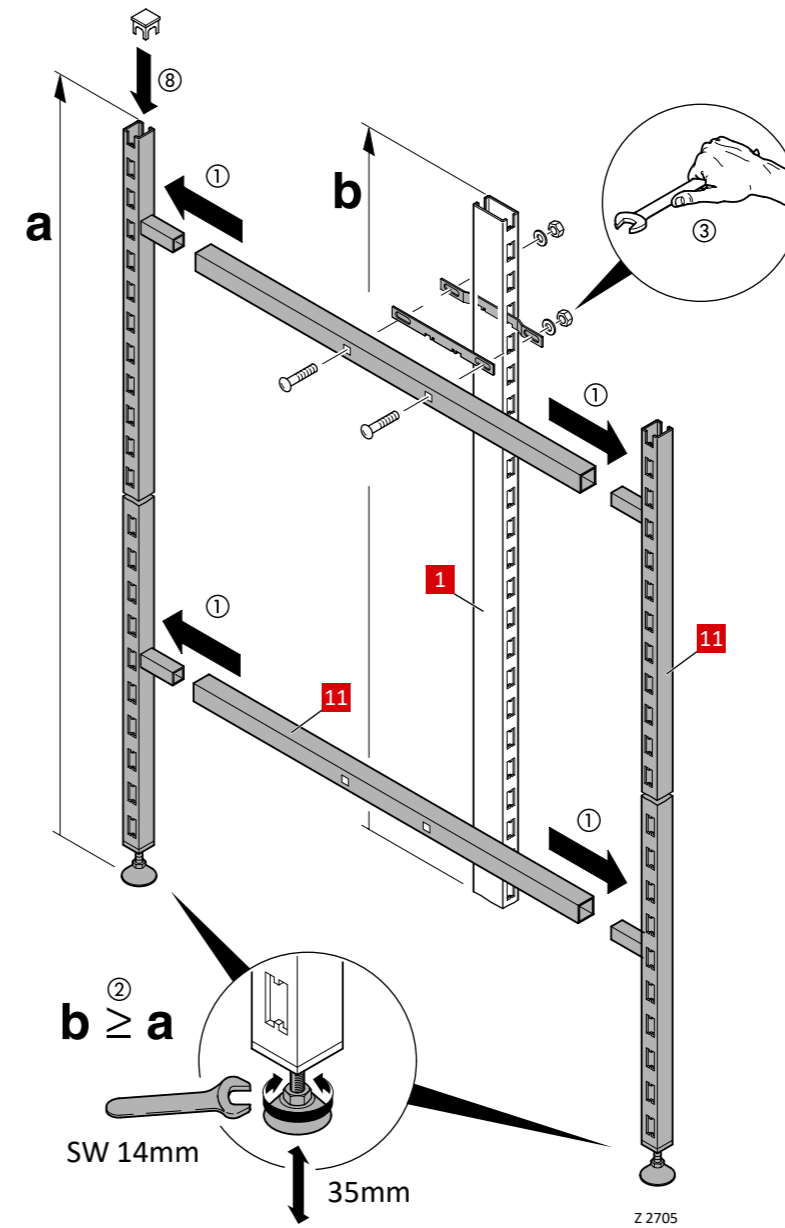
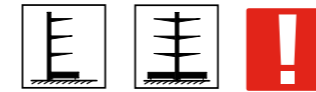

7.4 Gondola shelving face, double-sided back panel

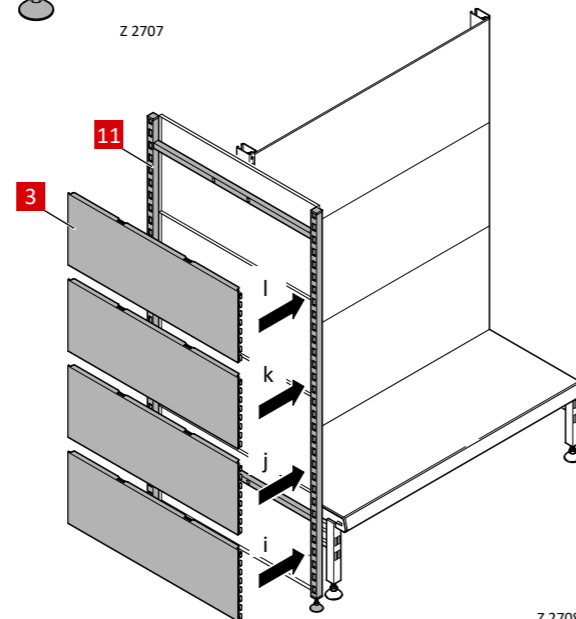
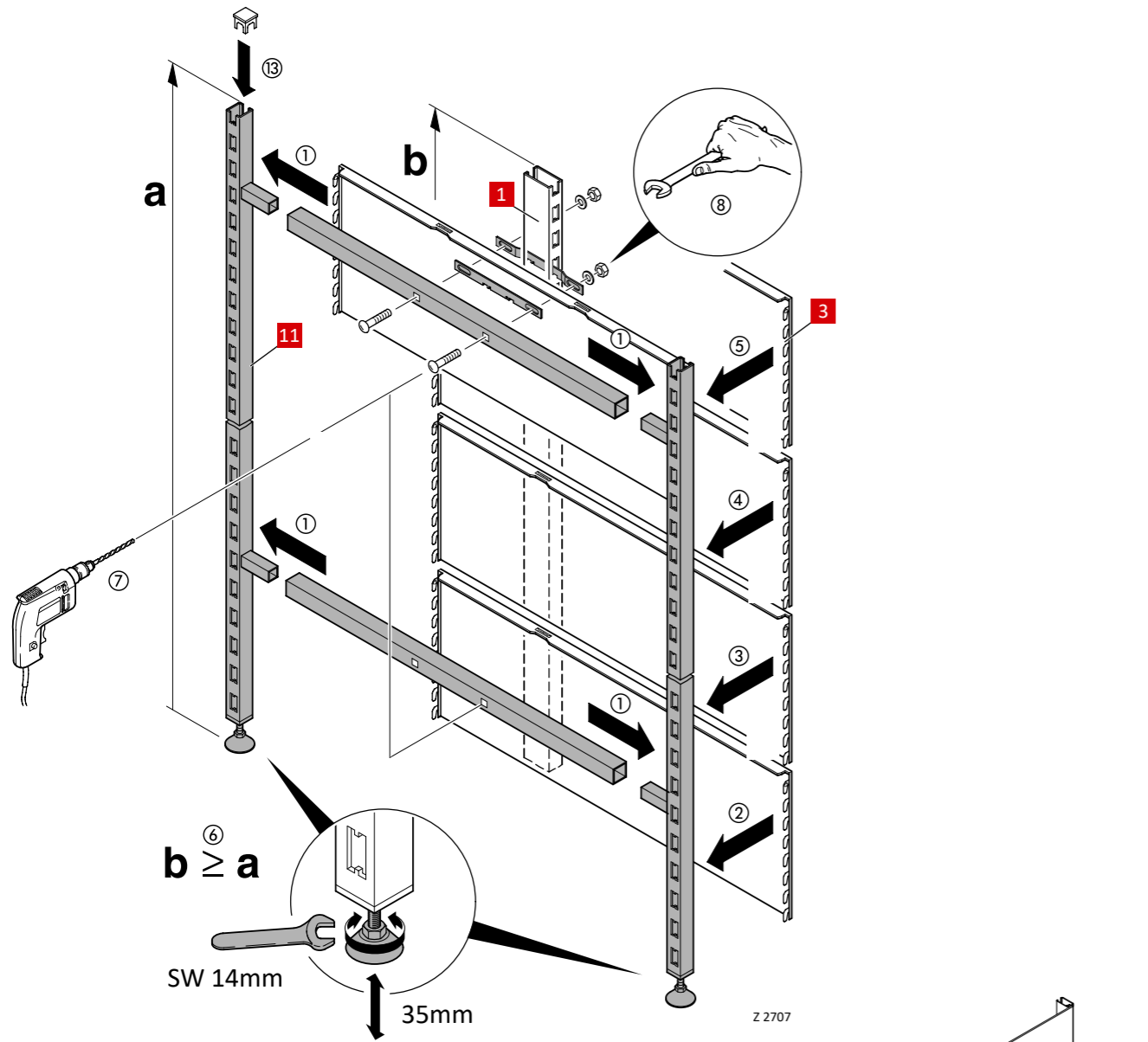
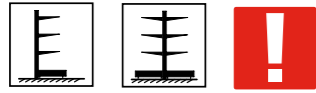

Chapter 3

Assembly instructions for fruit and vegetable shelves

- 1 Overview of the components for fruit and vegetable shelving and their function 24
- 2 Depiction of the shelving components and their function 25
 - 2.1 Back panel mounting 25
 - 2.2 Mirrors and fascia 26
 - 2.2.1 Mirror 1-piece 26
 - 2.2.2 Mirror 2-piece 26
 - 2.3 Large trough 27
 - 2.4 Fruit trough 28

1 Overview of shelf components for fruit and vegetable shelving and their function

- 1 Soffit – covers the top opening.
- 2 Lower soffit, shaped – to accommodate the lighting.
- 3 Fascia – for top front.
- 4 Side panel for fruit shelving with large trough and side panel.
- 5 Mirror holder – for mounting mirrors 1-piece.
- 6 Mirror.
- 7 Brackets for fruit shelving with large trough.
- 8 Shelf element for fruit tray.
- 9 Crash bar – protects the shelf from approaching shopping carts.
- 10 Front profile for large trough.
- 11 Plinth back panel.
- 12 Stand for fruit shelving with large trough.
- 13 Back panel.
- 14 Fascia bracket for fruit shelving.
- 15 Mirror holder – for mounting mirrors 2-piece.
- 16 Mirror, upper part.
- 17 Mirror, lower part.
- 18 Banana bar for fruit shelving.
- 19 End plates for fruit shelf.
- 20 Front profile for fruit tray.
- 21 Double bracket for fruit shelf.
- 22 Back panel – for front facing.
- 23 Crash bar – protects the shelf from approaching shopping carts.
- 24 Lateral plinth facing.
- 25 Stand for fruit shelving.
- 26 Back panel.
- 27 Facing side plates – side finish.
- 28 Fascia return for upper fascia.
- 29 Side panels.

2 Depiction of the shelving components and their function

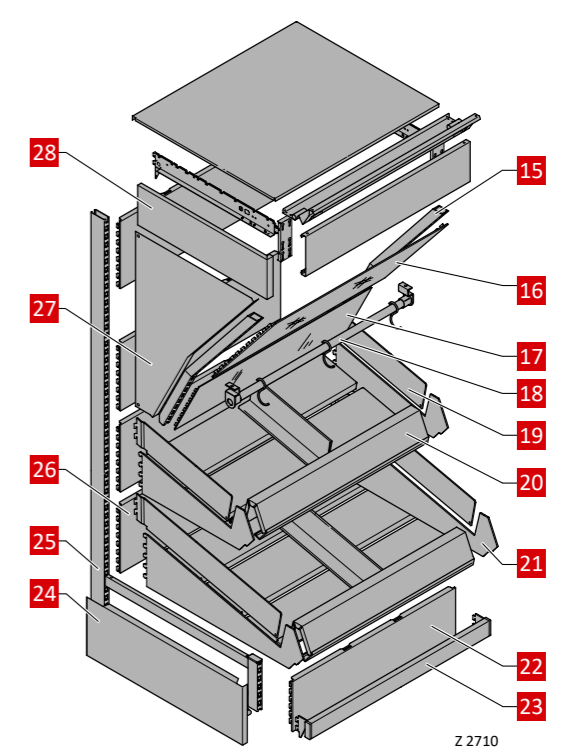
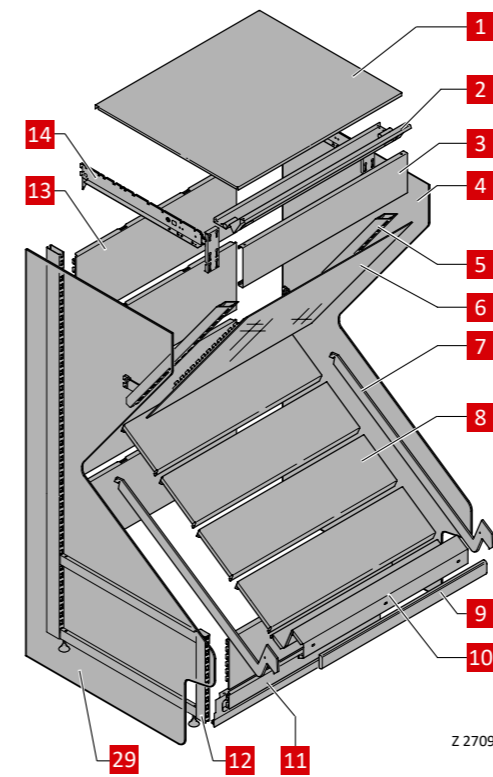

2.1 Back panel mounting

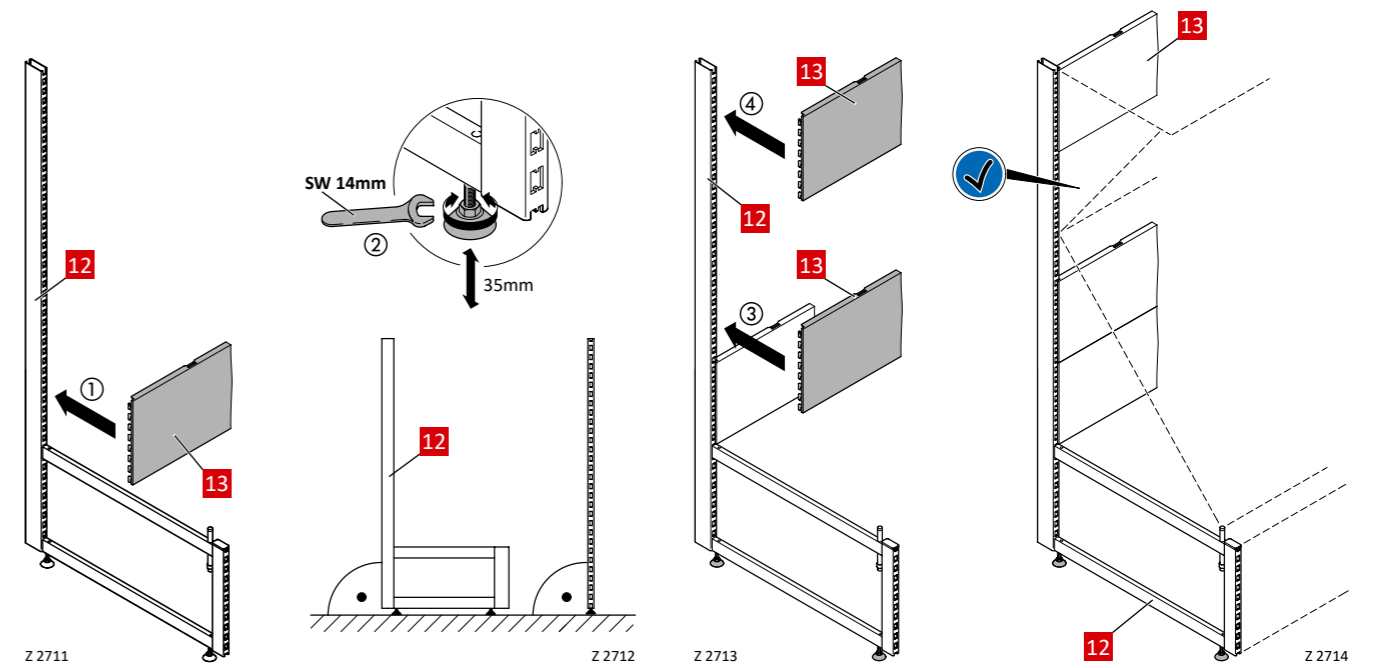

Assembly of fruit and vegetable shelves

2.2 Mirrors and fascia

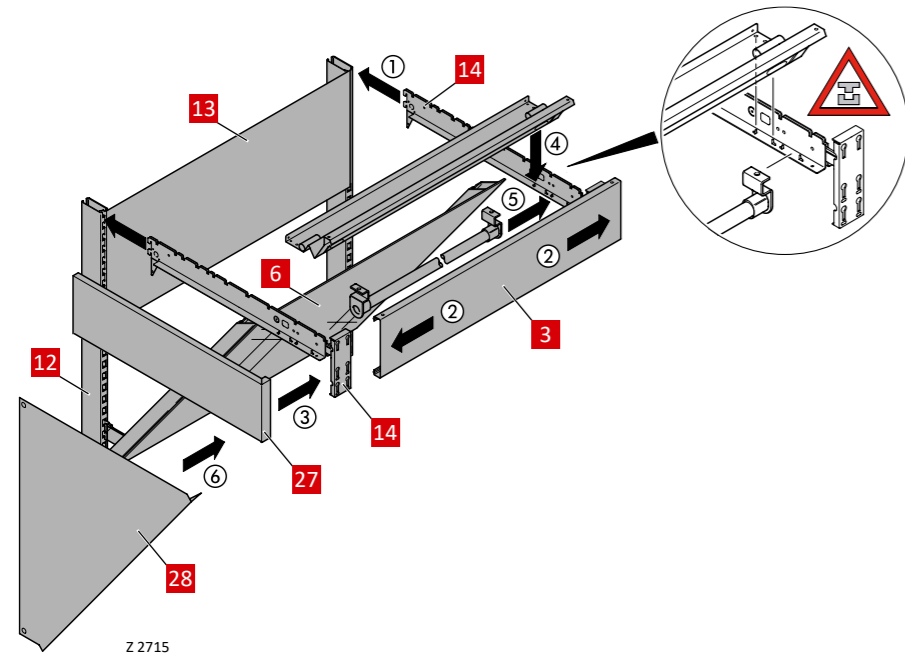

2.2.1 Mirror 1-piece

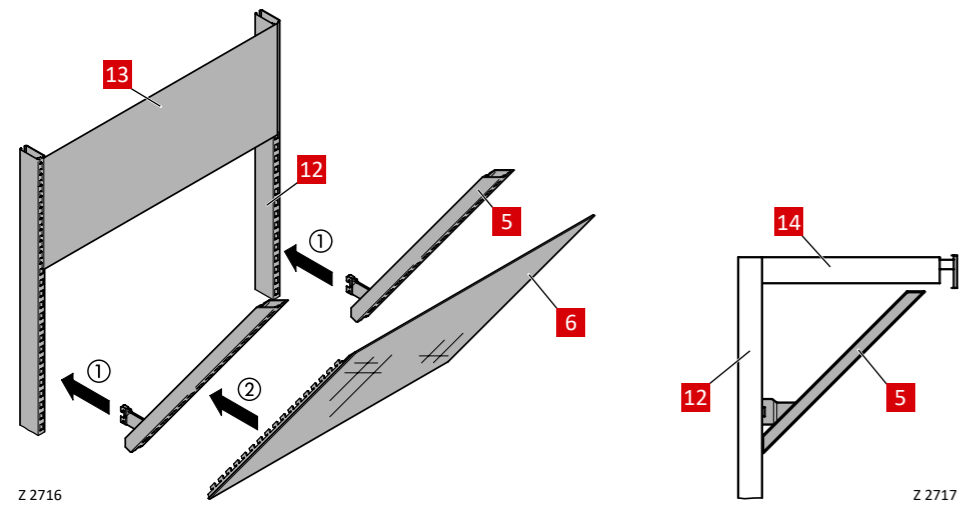

2.2.2 Mirror 2-piece

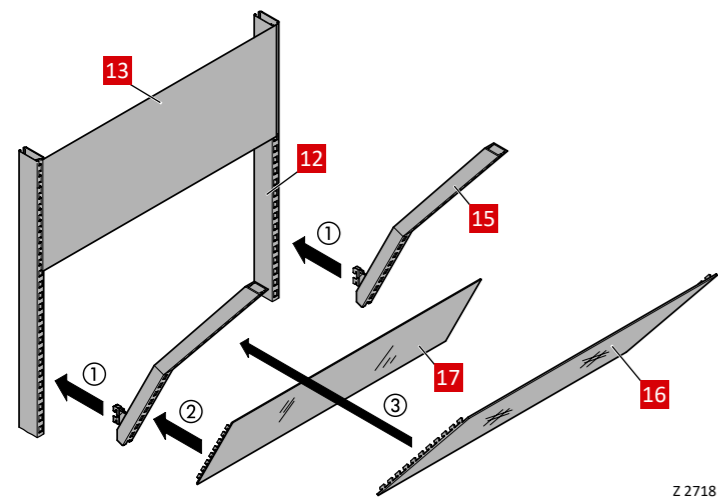

2.3 Large trough

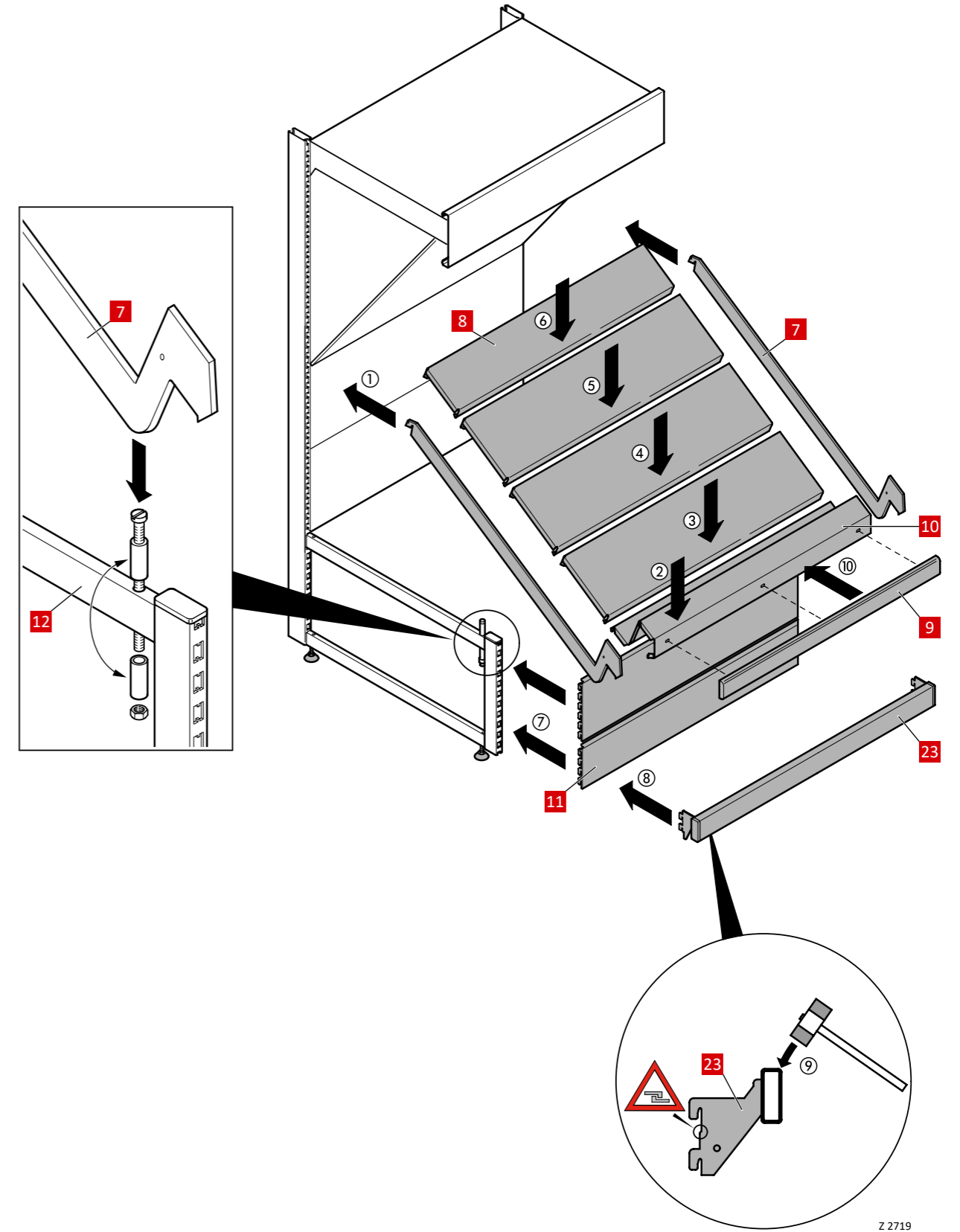

2.4 Fruit trough

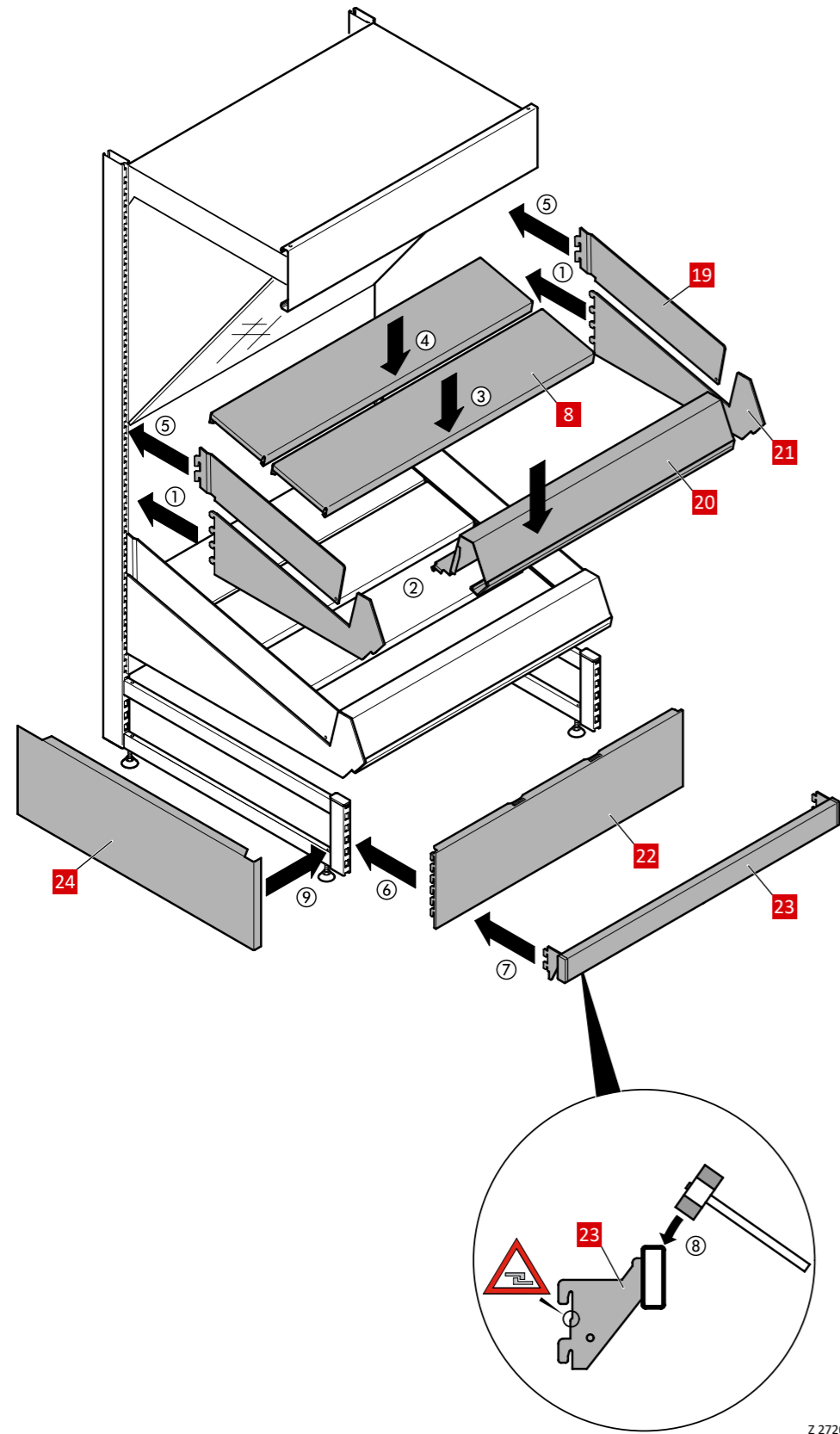

Z 2720

Chapter 4

Assembly instructions for fruit gondola with one or two shelves

1	Overview of the shelf components of the fruit gondolas and their function	30
1.1	Fruit gondola with one shelf.....	31
1.2	Fruit gondola with two shelves	31
2	Depiction of the shelf components of fruit gondola and its function	32
2.1	Fruit gondola with one bottom	32
2.2	Fruit gondola with two bottoms.....	33

1 Overview of the shelf components of the fruit gondolas and their function

- 1 Gondola cover strip.
- 2 Back panel.
- 3 Shelf element for fruit tray.
- 4 Double bracket for fruit shelf, top.
- 5 Corner facing for fruit gondola.
- 6 Back panel H 20.
- 7 Back panel H 30.
- 8 Plinth back panel H 10.
- 9 Plinth.
- 10 Crash bar – protects the shelf from approaching shopping carts.
- 11 Plinth.
- 12 Baseleg for fruit gondola.
- 13 Crash bar for fruit gondola, external corner – protects the shelf from approaching shopping carts.
- 14 Back panel for fruit gondola outside corner H 10.
- 15 Back panel for fruit gondola outside corner H 30.
- 16 Upright extension for fruit gondola.
- 17 Back panel for fruit gondola outside corner H 20.
- 18 Front profile for fruit gondola outer corner.
- 19 Shelf element for fruit gondola outer corner.
- 20 Stand for fruit gondola.
- 21 Top cap for stand.
- 22 Double bracket for fruit shelf, bottom.
- 23 Back panel safeguard.
- 24 Front profile for fruit gondola.

1.1 Fruit gondola with one shelf

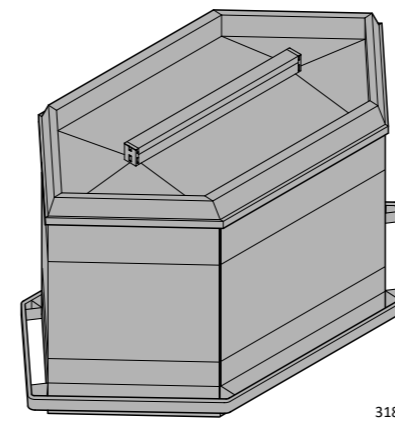

3186

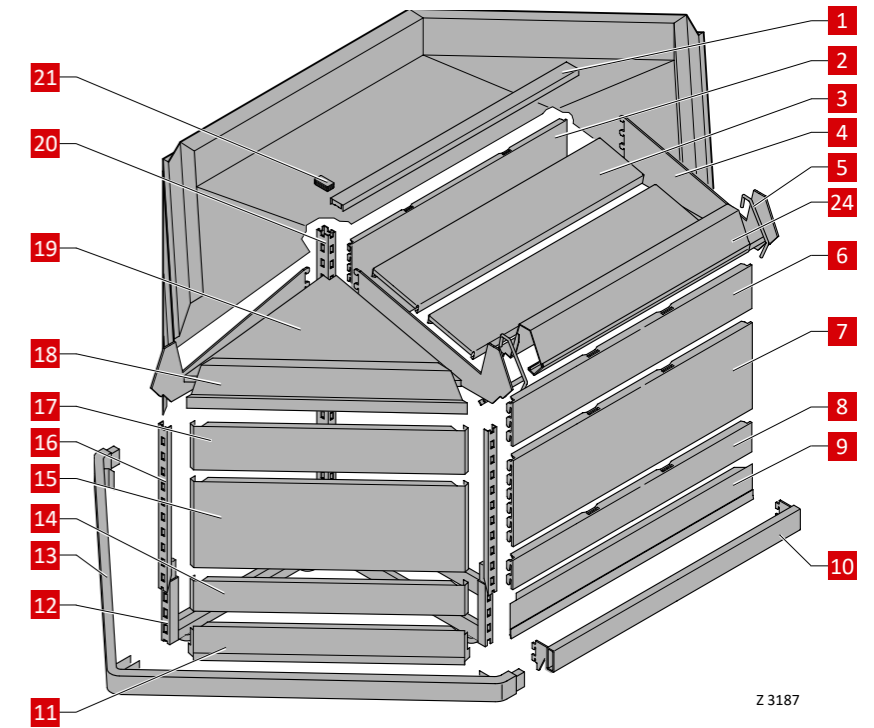

Z 3187

1.2 Fruit gondola with two shelves

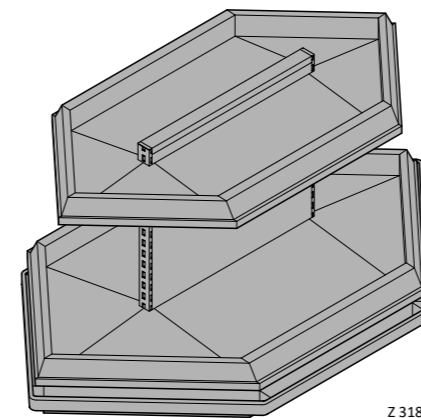

Z 3188

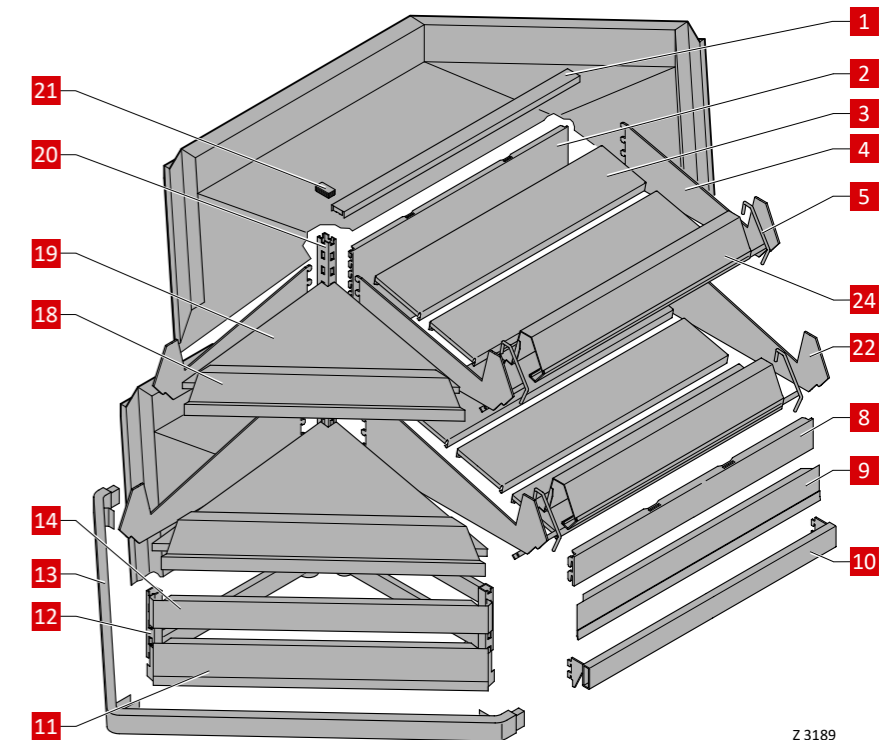

Z 3189

Assembly instructions for fruit gondola with one or two shelves

2 Depiction of the shelf components of fruit gondola and its function

2.1 Fruit gondola with one bottom

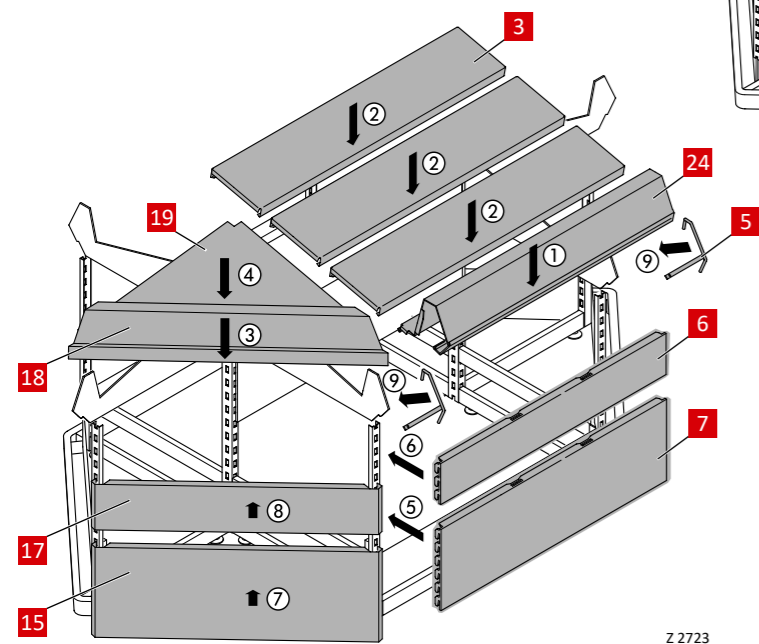
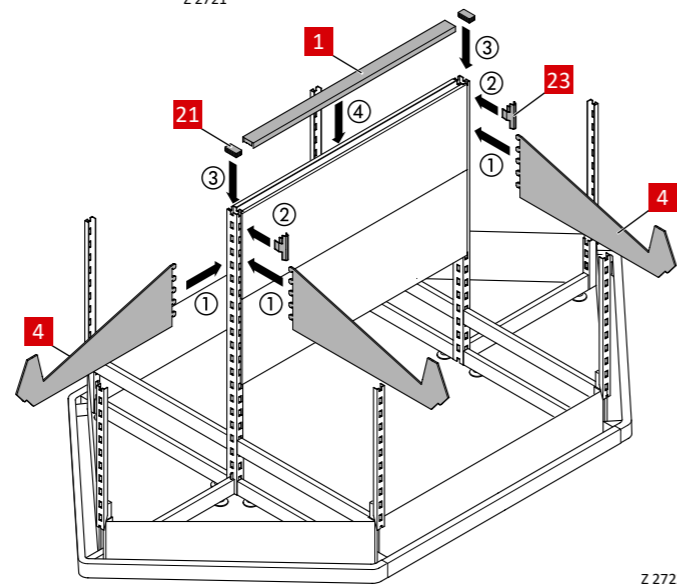
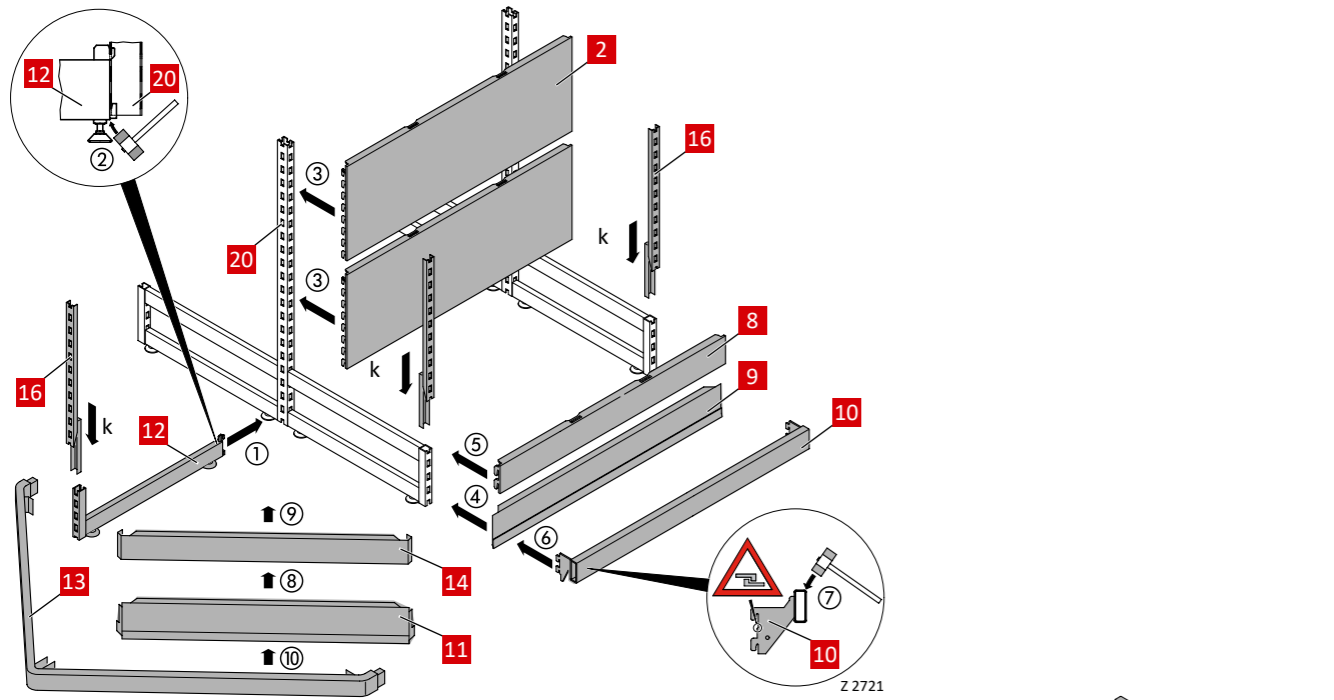

2.2 Fruit gondola with two bottoms

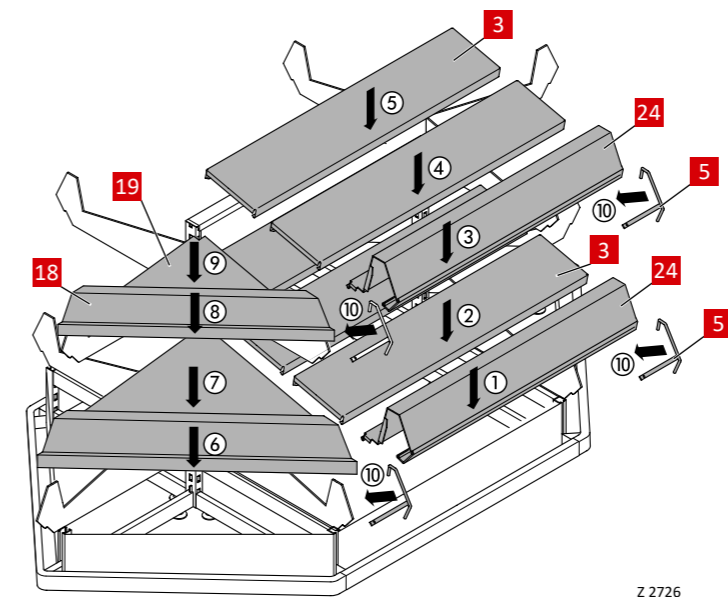
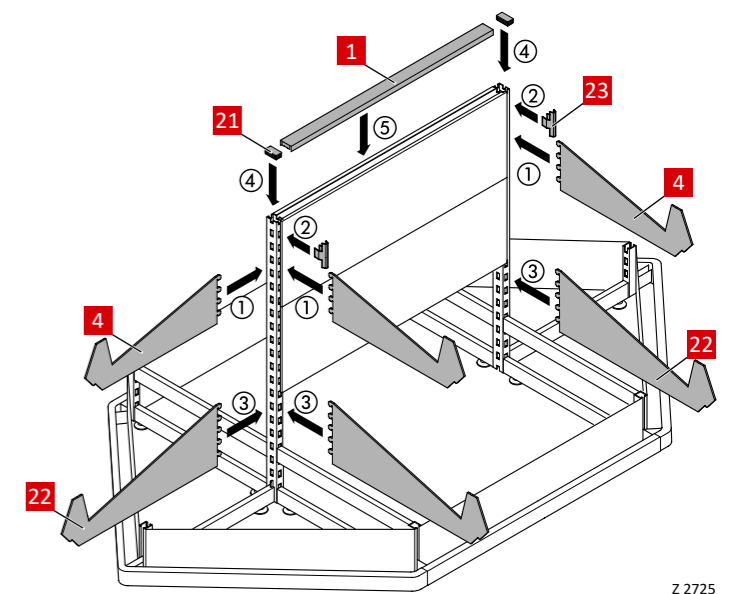
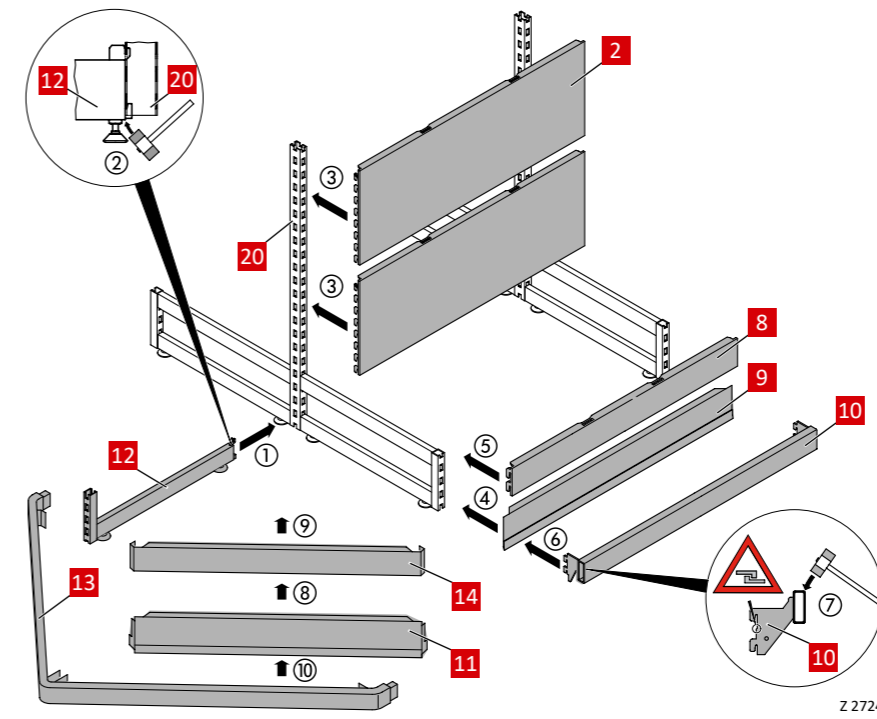

Chapter 5

Permissible loads

1	Permissible loads for wall shelves and gondolas.....	36
2	Permissible load for shelves on shelf brackets	36
3	Permissible load for shelves on baselegs	36
4	Permissible load of the shelves – maximum loading capacity – on extra heavy shelf brackets with 4 hooks or baselegs.....	37
5	Permissible load of grid shelves on shelf brackets or baselegs	37
6	Permissible load for baselegs H 8 for wall shelf uprights or gondolas	38
7	Permissible load for baseleg H 16 and H 26 for wall shelf stands and gondolas	38

1

2

3



4

5

1 Permissible loads for wall shelves and gondolas

- Uniformly distributed loading over the whole shelf is required.
- The permissible stand loads can be increased by wall fixings, if the means of fixing and wall are able to safely absorb and transfer the resulting additional loads; this must be checked on site.
- Equipping the shelving stands with bay load reducing upwards.
- Ensure that all push-on connections are properly fitted.
- The shelving must not be subjected to loads under impact.
- If the shelf's maximum loading capacity is utilised, the top back panels must be secured against uplift using the back panel safeguard 10 7154.
- If no load information is available or special load requirements exist, please contact our technical department.
- If both sides are loaded (gondola) the same loads can be applied on the right and left as for wall shelves.
- The loading of the baseleg shelves is given in Table 2.
- The uprights of wall shelves must be fixed with wall fixings from a height of 220cm.

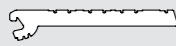
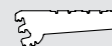
2 Permissible load for shelves on shelf brackets

Permissible load per shelf in daN = kg (Loading information for shelf brackets is only valid in conjunction with rectangular uprights)																
Support type	Shelf bracket 2 H  Z 1596				Shelf bracket 3 H  Z 1597		Shelf bracket extra heavy duty 3 H  Z 1426				Shelf bracket extra heavy duty 4 H  Z 1425					
Shelf depth in cm	D 25	D 30	D 37	D 47	D 47	D 57	D 37	D 47	D 57	D 67	D 37	D 47	D 57	D 67	D 77	
Axis spacing in cm	66.5	120	110	100	90	170	150	230	230	180	160	230	325	255	230	200
	100	120	110	100	90	170	150	200	230	180	160	200	290	255	230	200
	125	120	110	100	90	170	150	155	230	180	160	155	260	255	230	200
	133	120	110	100	90	170	150	140	230	180	160	140	230	250	230	200

Tab. 1 Permissible load per shelf in daN = kg (load specifications for shelf brackets are only valid in conjunction with rectangular columns).

3 Permissible load for shelves on baselegs

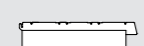
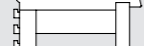
Permissible load per shelf in daN = kg (Loading information for shelf brackets is only valid in conjunction with rectangular uprights)						
Support type	Baselegs H 16 or H 26  Z 1600  Z 1601					
Shelf depth in cm	D 37	D 47	D 57	D 67	D 77	
Axis spacing in cm	66.5	230	290	350	450	360
	100	200	290	310	350	290
	125	155	260	270	310	270
	133	140	230	250	300	240



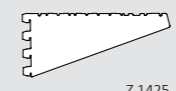
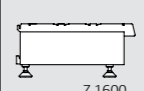
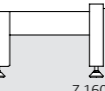

Tab. 2 Permissible load per shelf in daN = kg (load specifications for shelf brackets are only valid in conjunction with rectangular columns).

4 Permissible load of the shelves – maximum loading capacity – on extra heavy shelf brackets with 4 hooks or baselegs

Permissible load information (in kg) of the shelves – maximum loading capacity – on extra heavy shelf brackets with 4 hooks or baselegs							
Support type	Shelf brackets 4 H extra heavy duty  Z 1425			Baselegs H 16/H 26  Z 1600  Z 1601			
Shelf depth in cm	D 57	D 67	D 77	D 57	D 67	D 77	
Axis spacing in cm	100	255	230	200	500	540	500
	125	255	230	200	400	470	470
	133	255	230	200	380	400	450

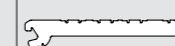
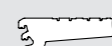
Tab. 3 Permissible load per shelf in daN = kg (load specifications for shelf brackets are only valid in conjunction with rectangular columns).

5 Permissible load of grid shelves on shelf brackets or baselegs

Permissible load per grid shelf in daN = kg (Loading information for shelf brackets and baselegs is only valid in conjunction with rectangular uprights)													
Support type	Shelf bracket 2 H  Z 1596		Shelf bracket 3 H  Z 1597		Shelf bracket heavy duty 3 H  Z 1426				Baselegs H 16 or H 26  Z 1600  Z 1601				
Shelf depth in cm	D 37	D 47	D 47	D 57	D 37	D 47	D 57	D 67	D 37	D 47	D 57	D 67	
Axis spacing in cm	66.5	100	90	170	150	200	230	180	160	200	230	250	450
	100	100	90	170	150	130	180	180	160	130	180	180	350
	125	100	90	170	150	130	170	180	160	130	170	180	250
	133	100	90	160	150	130	160	180	160	130	160	180	200

Tab. 4 Permissible load per grid shelf in daN = kg (load specifications for shelf brackets are only valid in conjunction with rectangular columns).

6 Permissible load for baseleg H 8 for wall shelf stands and gondolas
(perm. total load of all shelves not including baseleg shelves in daN = kg)

Calculation of the average depth:

The average depth is calculated from the sum of the depths of the shelves – not including the baseleg shelf – divided by the number of shelves – not including the baseleg shelf.

Example:

Sum of all shelves not including baseleg shelf:

$$25 + 37 + 37 + 47 = 146$$

Number of shelves not including baseleg shelf: 4

$$146/4 = 36.5$$

Upright	Permissible total load [kg] for average depth D	
	D 30/D 37 Baseleg depth of at least 47cm	D 47 Baseleg depth of at least 57cm
50x30	150	120
60x30	230	180
80x30	250	200
110x30	250	200

Tab. 5 Permissible total load as a function of the average depth D of the wall shelf uprights and an H 8 baseleg.

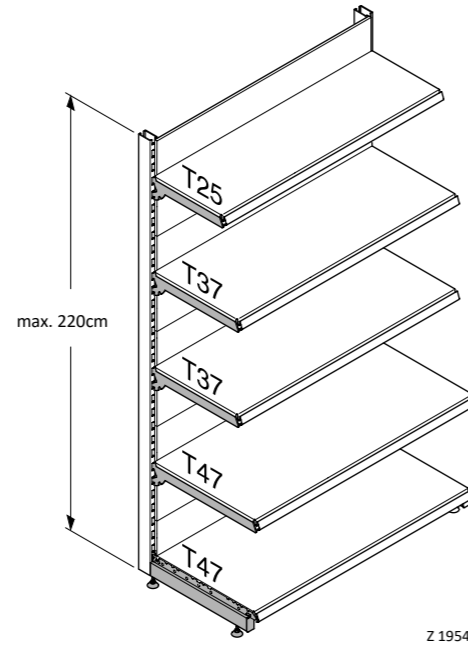

Fig. 1 Wall shelf stands with an average depth D 37 and a baseleg shelf D 47.

7 Permissible load for baseleg H 16 and H 26 for wall shelf stands and gondolas
(perm. total load of all shelves not including baseleg shelves in daN = kg)

Calculation of the average depth:

The average depth is calculated from the sum of the depths of the shelves – not including the baseleg shelf – divided by the number of shelves – not including the baseleg shelf.

Example:

Sum of all shelves not including baseleg shelf:

$$37 + 47 + 47 + 47 + 57 = 235$$

Number of shelves not including baseleg shelf: 5

$$235 / 5 = 47$$

Upright	Permissible total load [kg] for average depth D				
	D 37 Baseleg depth of min. 47cm	D 47 Baseleg depth of min. 57cm	D 57 Baseleg depth of min. 67cm	D 67 Baseleg depth of min. 77cm	D 77 Baseleg depth of min. 77cm
50x30	180	130	100		
60x30	250	200	150	–	–
80x30	400	350	300	250	200
110x30	600	500	450	400	400

Tab. 6 Permissible total load as a function of the average depth D of the wall shelf uprights and an H 16 or H 26 baseleg.

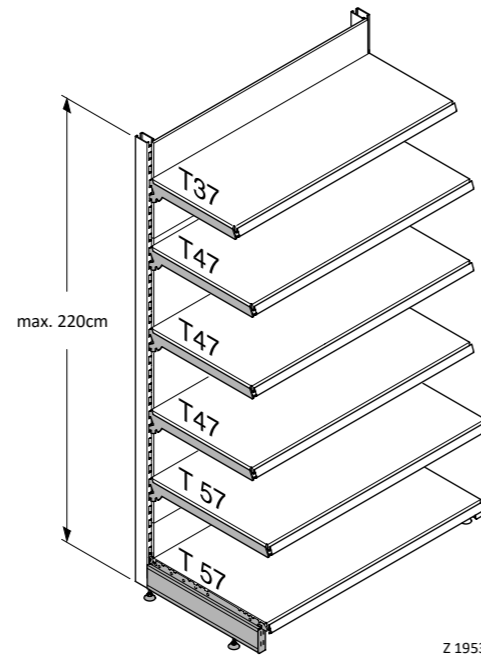

Fig. 2 Wall shelf stands with an average depth D 47 and a baseleg shelf D 57.

Tegometall